



**DAN MURPHY'S
FORMAT MASTERPLAN 2022.1 KIT
LARGE STORE FORMAT
ELECTRICAL SPECIFICATION**

REVISION A
ISSUE DATE - 20.10.2021



REVISIONS

AMENDMENT	DATE	REVISION
General Issue	07/10/2021	A

CHANGES

From 2017.1 Dan Murphy's Electrical Specification Rev A.

SECTION	DESCRIPTION
4.22 EMERGENCY LIGHTING SYSTEM	New requirements.
4.32 STRUCTURED CABLING SYSTEM	New requirements as per latest Woolworths Stores SCS Specification.
4.34 MASTER ANTENNA TELEVISION (MATV) SYSTEM	New requirement.
4.35 MOBILE NETWORK 'YAGI' ANTENNA CABLING	New requirement.
4.36 NBN SERVICES RELOCATION	New requirement.
APPENDIX C – TRACK LIGHT AIMING INSTRUCTIONS	New requirement.
APPENDIX D – LIGHTING SUSPENSION INSTALLATION GUIDE	New requirement.
General	Deletion of Power Factor Correction Equipment.
General	New power, data, lighting, PA, Security & CCTV services layouts.

TABLE OF CONTENTS

1. PREAMBLE	6
2. APPROVED CONTRACTORS AND SUPPLIERS	7
2.1 APPROVED ELECTRICAL CONTRACTORS	7
2.2 APPROVED SERVICES AND EQUIPMENT SUPPLIERS	8
3. GENERAL CONDITIONS OF CONTRACT	10
3.1 DEFINITION OF TERMS	10
3.2 SCOPE OF WORKS	10
3.3 EXTENT OF CONTRACT & TENDERING	10
3.4 WORK BY OTHERS	11
3.5 WORKING DRAWINGS & SPECIFICATIONS	11
3.6 REGULATIONS AND FEES	12
3.7 ELECTRICAL & COMMUNICATION CABLING LICENSES	12
3.8 COMPLIANCE TO AUSTRALIAN STANDARDS	12
3.9 INSURANCE	12
3.10 PATENT RIGHTS	13
3.11 PROTECTION OF PLANT MATERIALS & PROPERTY	13
3.12 SITE FOREMAN	13
3.13 VARIATIONS	13
3.14 TIME OF COMPLETION & LIQUIDATED DAMAGES	13
3.15 DEFECTS AND CERTIFICATION OF PRACTICAL COMPLETION	14
3.16 WARRANTY	14
3.17 CUTTING & CHASING	14
3.18 STORAGE	15
3.19 TESTING & COMMISSIONING	15
3.20 OH&S REQUIREMENTS FOR CONSTRUCTION	15
3.21 SITE ACCESS	15
3.22 GENERAL PUTTING INTO SERVICE	15
3.23 CO-ORDINATION	16
3.24 DRAWING SCHEDULE	16
3.25 TEMPORARY ELECTRICAL PROVISIONS	16
4. TECHNICAL REQUIREMENTS	17
4.1 EXTENT OF WORKS	17
4.2 SUPPLY	17
4.3 BALANCING OF ELECTRICAL INSTALLATION	18
4.4 VOLTAGE DROP	18
4.5 TARIFF METERING	18
4.6 EARTHING	18
4.7 CONSUMER MAINS & SUBMAINS	19
4.8 STORE MAIN SWITCHBOARD	20
4.9 DISTRIBUTION BOARDS	25
4.10 CASCADING AND DISCRIMINATION	27
4.11 CABLING SUPPORT SYSTEM	27
4.12 CONDUITS & FITTINGS	28
4.13 CABLE TRAY & CABLE LADDER	30
4.14 WIRING AND CABLING	32
4.15 ELECTRICAL ACCESSORIES	34
4.16 INSTALLATION OF EQUIPMENT	35
4.17 POWER SUPPLY TO OTHER SERVICES AND SYSTEMS	36
4.18 LABELLING OF ACCESSORIES & EQUIPMENT	36
4.19 LIGHTING REQUIREMENTS	37

4.20	ILLUMINATED SIGNS	39
4.21	CAR PARK LIGHTING	39
4.22	EMERGENCY LIGHTING SYSTEM.....	41
4.23	BELL SYSTEM	43
4.24	SECURITY ALARM AND CCTV SYSTEMS.....	44
4.25	PUBLIC ADDRESS SYSTEM (PA)	44
4.26	MECHANICAL AND REFRIGERATION SYSTEMS	45
4.27	MECHANICAL FIRE TRIP (WORK BY OTHERS)	45
4.28	FIRE SERVICE	45
4.29	FINISHES	47
4.30	STANDBY GENERATING SET	47
4.31	ENERGY MANAGEMENT SYSTEM (EMS).....	49
4.32	STRUCTURED CABLING SYSTEM.....	51
4.33	UNINTERRUPTIBLE POWER SUPPLY (UPS).....	52
4.34	MASTER ANTENNA TELEVISION (MATV) SYSTEM	52
4.35	MOBILE NETWORK 'YAGI' ANTENNA CABLING	53
4.36	NBN SERVICES RELOCATION	53
5.	TESTING APPROVALS & MAINTENANCE MANUALS	54
5.1	GENERAL REQUIREMENTS	54
5.2	TESTS AND APPROVALS.....	54
6.	OPERATION AND MAINTENANCE MANUALS	56
6.1	INSTRUCTION MANUALS, CIRCUIT DIAGRAMS & DRAWINGS.....	56
6.2	SCS CABLING SYSTEM RECORDS AND DOCUMENTATION FOLDER	57
6.0	DAN MURPHY'S STANDARD DRAWINGS.....	58
	APPENDIX A – CONTRACTORS COMPLIANCE CERTIFICATE	59
	APPENDIX B – LIGHTING OPERATING HOURS REQUEST FORM.....	60
	APPENDIX C – TRACK LIGHT AIMING INSTRUCTIONS.....	61
	APPENDIX D – LIGHTING SUSPENSION INSTALLATION GUIDE	62

1. PREAMBLE

This Electrical Specification shall be read in conjunction with the other elements of the issued Design Brief prepared by Endeavour Group, including the standard architectural and electrical services drawings. These drawings will be standard details unless superseded by a particular control plan.

It is not intended that Lessors provide Telephone Handsets, Electronic Article Surveillance Systems, CCTV and Security Alarm Systems, Satellite Music and Public Address Systems, as described herein and illustrated on the drawings. However, Lessors are to provide lighting, power, switchboards, generator, in-store SCS communication systems, all conduits and wall boxes necessary to service the above-mentioned separate contracts, which will be arranged by Endeavour Group and carried out by others. The Contractor shall liaise with the appropriate suppliers to ensure a completed installation.

The Lighting, Data and Power Installation specify the visual and functional retail design criteria required. The Contractor shall ensure that all Electrical and Communication Installation fully conform to this Specification and Drawings.

All equipment, cabling and accessories for the In-Store Communication Systems shall conform in design, material, construction, workmanship and performance to the requirements specified in this Electrical Specification and the latest Woolworths IT Structured Cabling System Specification. The Contractor installing the Structured Cabling System shall be selected from the Approved SCS Data Contractor List. This is an essential requirement for ensuring all the Point of Sales, computerised equipment and facilities operate satisfactory in the store and enabling Endeavour Group to have a minimum 15-year Product Warranty and Application Assurance Program provided by the approved Structured Cabling System supplier(s).

Where a Consulting Engineer is engaged by the Lessor to carry out detail designs, the Consulting Engineer shall, during the course of the project, carry out not less than three (3) site inspections and issue progress reports to Endeavour Group, that is, 2 evenly spaced inspections during construction, and 1 at handover. The Consulting Engineer must ensure that all defects noted during the inspections are rectified by the Contractor.

This document is issued only for the project noted on the cover page. Its use for any other project is specifically discouraged. Furthermore, it should be realised that precedent is not sufficient reason for proposing alternative materials or methods. This specification is constantly under review and the circumstances surrounding previous decisions may no longer be applicable.

2. APPROVED CONTRACTORS AND SUPPLIERS

2.1 APPROVED ELECTRICAL CONTRACTORS

In the interests of maintenance, standardisation and to provide a satisfactory installation and warranties to conform to Endeavour Group operational and maintenance requirements, a number of Electrical Contractors have been pre-qualified and approved by Endeavour Group for each state.

The SCS works shall form part of the Electrical Contractors works. These works are described in a separate specification produced by Woolworths IT on behalf of Endeavour Group. The SCS Contractor shall be selected from the approved Contractor List in the SCS Specification. The Electrical Contractor shall engage the services of this licensed SCS Contractor to carry out the SCS works.

Final design documentation for electrical and communication installation shall be submitted to Endeavour Group for approval. It is the Contractor's responsibility to ensure the entire electrical and communication design conforms to Endeavour Group's operational and maintenance requirements prior to commencement of work on site.

The Electrical Contractor shall be selected from the following approved Electrical Contractors list.

WESTERN AUSTRALIA		
Everett Smith Pty Ltd	58 Howe Street Osborne Park WA 6017	(08) 9444 8800
Downer RML Pty Ltd	9 Modal Crescent, Canning Vale WA 6155	(08) 9318 9111
S.J. Electric (WA) Pty Ltd	9 Roberts Street (West), Osborne Park WA 6017	(08) 9470 4292
TES Electrical	18 Hammond Road, Cockburn Central WA 6164	(08) 9434 1514
Recom Electrical Services Pty Ltd	Unit 2, 34 Hasler Road Osborne Park WA 6017	(02) 9881 5877
QUEENSLAND		
S.J. Electric (QLD) Pty Ltd	19 Elliot St Albion QLD 4010	(07) 3256 1522
Stowe Australia	23 Hi-Tech Court Eight Mile Plains QLD 4113	(07) 3423 6777
Recom Electrical Services Pty Ltd	10/5-7 Cairns Street, Loganholme QLD 4129	(07) 3139 0333
MEC Electrical Solutions Pty Ltd	30 Uplands Drive, Parkwood QLD 4214	(07) 5563 3533
kW Electric	Unit 2/17 Commerce Circuit Yatala Qld 4207	(07) 3287 2766
SOUTH AUSTRALIA & NORTHERN TERRITORY		
S.J. Electric (SA) Pty Ltd	8A Armiger Court Holden Hill SA 5088	(08) 8396 1822
Tad-Mar Electrical Pty Ltd	8 Dundee Ave Holden Hill SA 5088	(08) 82614144
Recom Electrical Services Pty Ltd	PO Box 210, Dry Creek SA 5094	(02) 9881 5877
NEW SOUTH WALES		
DDP Electrical Services Pty Ltd	Unit 1, 11 Stoddart Road, Prospect NSW 2148	(02) 9896 0664
Kevin R Sheather Northern	1/6 Ketch Close Fountaindale NSW 2258	(02) 4367 6255

SJ Electric (NSW) Pty Ltd	14a Lidco Street Arndell Park NSW 2148	(02) 9672 0400
Recom Electrical Services Pty Ltd	1/79 Newton Road, Wetherill Park NSW 2164	(02) 9881 5877
Servcore	Unit 8, 5/7 Meridian Place, Bella Vista NSW 2153	1300 605 040
Coppercore Installations Pty Ltd	Unit 2, 19 Devon Rd Ingleburn, NSW, 2565	1300 441 552
Stowe Electrical - Taree Branch only	12 Elizabeth Street, Taree NSW 2430	(02) 6552 6411
Hanaca Electrical Services	5/24 Yalgar Rd, Kirrawee NSW 2232	(02) 9521 8914
VICTORIA & TASMANIA		
Prime Electrical	10-12 Beatrice Ave Heidelberg West Vic 3081	(03) 9457 5122
SJ Electric (Vic) Pty Ltd	76 Commercial Drive Thomastown VIC 3074	(03) 9466 3977
Modec Electrical	78-86 Newlands Road Coburg North VIC 3058	(03) 9350 2855
Stowe Australia	67-69 Buckhurst Street South Melbourne VIC 3205	(03) 9695 2333
Apex Electrical Contracting	Unit 2/68 Wirraway Drive, Port Melbourne Vic, 3207	(03) 8420 3333
M+G Electrical	49 Sackville St, Collingwood VIC 3066	(03) 9417 3011
Recom Electrical Services Pty Ltd	96 Logistics Street, Tullamarine VIC 3043	(03) 9336 0016
Vast Electrical	6 Dilop Drive, Epping VIC 3076	(03) 8401 4940
Seven 20 Electrical	4/810 Mountain Hwy Bayswater VIC 3153	(03) 9729 2281
BSH Electrical P/L	213 Harrington St Hobart Tas 7000	(03) 6231 0255

2.2 APPROVED SERVICES AND EQUIPMENT SUPPLIERS

To achieve the desired effect, the Contractor shall purchase and provide the Electrical and SCS Services using the following Approved Services and Equipment Suppliers.

Where any item or component is nominated in this Specification by name of the manufacturer, such items or components shall be used. The expressions 'or similar' allows the substitution of components only with the written approval of Endeavour Group Electrical Engineer. Any request for such approval shall be accompanied by supporting performance statutory requirements, capital and maintenance cost savings, etc.

The following Services and Equipment suppliers/manufacturers have been accepted and registered by Endeavour Group.

<u>Item</u>	<u>Supplier Details</u>
Switchboards	G B Electric, K E Brown, Price Trandos Engineering, RG Ladd, Trivantage, SMB Macquarie.
Circuit Breakers	NHP (Terasaki) Schneider (Merlin Gerlin)

<u>Item</u>	<u>Supplier Details</u>
Contractors/Relays	NHP (Sprecher & Schuh) Schneider (Telemecanique)
Standby Generator	Powerlite, Eneraque
Indoor LED luminaires	As listed in Dan Murphy's standard lighting concept plan
Emergency and EXIT Lighting	As listed in Dan Murphy's standard lighting concept plan
Carpark LED Lighting	LSI Hamilton Advanced Lighting Technologies
SCS Cabling System	Refer Latest Woolworths Stores SCS Specification
Fire Rated Cables	MIMS, Radox, Fireguard
Fireproof block	Macwil Roxtec Multidiameter Rox Gland M63
Office 3-Channel Metal Ducts	ECD CM 150/50 3-channel Black Cableway 3-channel Black Note: Data and power outlets to be BLACK on black metal ducts.
Service Pole (for Service desk and check-outs)	ECD, Cableway
Cable Trays & Cable Ladders	Ezystrut, Unistrut
Cable Basket	Cabac, Cablofil, Unistrut (Acrofil)
Lighting Hanger Suspension System	Gripple Polyplas for lighting tracks
Hanger Suspension System	Threaded rods for cable trays, cable ladders and lighting ladder trays.
Lighting Energy Management System	Emerson
Light Switches and Switched Socket Outlets	Clipsal 2000 Series, Clipsal Pro series, HPM XL Series, PDL 600 series
Switched socket outlet with integrated USB charger	HPM Excel double powerpoint with USB charger, white finish, order code XL777USB2PSWE, or Clipsal C2000 Series double outlet + 30USBCM USB mechanism, white finish. Note: Change above to Black finish where black GPOs are used.
IP56 Switches and IP56 Switched Socket Outlets	Clipsal 56 Series, NHP ISO Range, IPD W66 Series

3. GENERAL CONDITIONS OF CONTRACT

3.1 DEFINITION OF TERMS

- 'Proprietor' shall mean Endeavour Group, owner of Dan Murphy's.
- 'Builder' shall mean the Building Contractor carrying out the general building work.
- 'Contractor' shall mean the successful tenderer selected to perform the electrical and SCS works described in the Specification.
- 'Engineer' or 'Endeavour Group Engineer' shall mean Endeavour Group Electrical Engineer or nominated representative.
- 'Approved' shall mean approved by Endeavour Group irrespective of any trade usage.
- "Project Manager" shall mean nominated manager approved by the Proprietor.

3.2 SCOPE OF WORKS

The works covered by this Contract shall comprise the supply, delivery to site, installation, testing, commission and warranty of the Electrical and SCS services described in the following documents:

- This Electrical Specification.
- Dan Murphy's Standard Drawings
- Woolworths Structured Cabling Specification – Latest version.
- All Addenda/Change Notifications associated with this Electrical Specification and Standard Electrical Drawings.

It is the Contractors responsibility to ensure that all electrical works are carried out for all items shown on the Control Plan, Internal & External Elevations Plans, Demolition Plan and Reflected Ceiling Plan even though these may not be specifically called for in this Specification.

3.3 EXTENT OF CONTRACT & TENDERING

3.3.1 GENERAL

The Contractor shall provide all materials and equipment and perform all work necessary for the complete and satisfactory operation of the whole of the electrical installation from the consumer terminals, except where specifically excluded in the Specification.

3.3.2 CONDITION OF SUBCONTRACT

The successful Contractor shall become a Sub-Contractor to the Builder. The Sub-Contractor shall be required to enter into a contract with the Builder within two weeks of his tender being accepted.

3.3.3 TENDERING

In submitting a price in accordance with this Specification, the Contractor shall be deemed to have visited the Store and is fully conversant with the conditions, requirements and extent of the works.

The Contractor shall submit a fixed lump sum price valid for 90 days. Provisional Sum and Rise and Fall proposals shall not be accepted.

Each item, as set out in the Schedule of Works, shall be shown as a separate cost. If any item does not proceed, then the cost shown for that item shall be deducted from the total lump sum tender price.

The fixed lump sum tender price shall be exclusive of GST. All tax invoices submitted by the Contractor for progress claims to be shown at net price plus GST Tax with

Australian Business Number (ABN).

The Contractor shall allow for all applicable site allowances, profit, handling charges for materials, travelling, accommodation and living away from home allowances in their tender price.

3.4 WORK BY OTHERS

The following items shall be provided by the Builder or carried out by others. The Electrical Contractor shall liaise and co-ordinate.

- Normal attendance and 'building-in'.
- Supply and installation of hot water and boiling water units and connection of water thereto.
- Supply and installation of electrical hand dryers if required.
- Supply and installation of building and tower signs.
- Provision of additional ceiling supports to carry the weight of light fittings.
- Supply, connection and testing of all in store computer equipment.
- Supply and installation of Mechanical Services and MSSB switchboard. However, sub-mains complete with cable supports thereto shall be supplied and connected to the terminals of the MSSB by the Contractor. All further work associated with the Mechanical System shall be performed by the Mechanical Contractor.
- Supply and installation of Refrigeration Services and switchboard. However, sub-mains complete with cable supports thereto shall be supplied and connected to the refrigeration switchboard by the Contractor. All further work associated with the refrigeration system will be performed by the Refrigeration Contractor.
- Supply and installation of Telephone Handset, scanning systems, PA, UPS, EAS, Security and CCTV, and satellite music systems.
- Supply and installation of Computer hardware and software retail scanning system.
- Supply and installation of Emerson Energy Management System.

3.5 WORKING DRAWINGS & SPECIFICATIONS

Submit all shop and working drawings to the relevant Authorities for approval prior to the commencement of works on site.

Approved copies and all layout drawings shall be submitted to Endeavour Group prior to commencement of associated works.

The drawings shall be prepared by the Contractor and shall include, but not be limited to the following:

- Lighting layout including switching and circuiting.
- Power layout including circuiting,
- Consumer mains, submains, cable trays, ducts and underground conduits layouts.
- SCS outlets and equipment layouts including schematic diagrams.
- Workshop drawings of all switchboards, including the site main switchboard supplying the store if applicable.
- Circuit diagrams and installation details.
- Site reticulation drawings.
- Site reticulation drawings, including voltage drop calculations.

Submit all shop, working and as-installed drawings in accordance with Dan Murphy's graphical symbol requirements.

Floor mounted conduit outlets in the trading area need to be positioned with great care. Accordingly, drawings shall show dimensions from the reference grid lines to all trading area floor outlet locations.

Where standard drawings give instructions regarding the location of other points, this information shall also be carried onto the working drawings.

Standard details shall also be transferred to working drawings. These shall include any modification caused by alteration to or mirror reversal of the basic plan. Standard drawings shall not be used on site, nor shall they be referred to in working drawings.

Prepare a specification incorporating all relevant details of these briefing documents. Where the stores components are only part of a larger development it is essential that parts of the specification relevant to this component are clearly identified. It is not acceptable to just reproduce this document as a specification or place amending sections late in the specifications.

Endeavour Group shall not be regarded as the Contractors checking agent. Approval of any document is given in principal only and without prejudice to the responsibility of the Contractor for proper co-ordination, installation and operation of the services in accordance with the requirements of the specification and drawing, and any others having jurisdiction over the works.

3.6 REGULATIONS AND FEES

All work performed under this Contract shall comply in every respect with the rules and regulations of all properly constituted Authorities having jurisdiction over installations in the district under consideration. The Contractor shall obtain all notices, obtain all consent necessary for the various works to be performed and pay all fees required by these Authorities with the exception of capital contributions to upgrade of existing substation or establishing new substation.

3.7 ELECTRICAL & COMMUNICATION CABLING LICENSES

Electricians engaged to carry out work under the contract shall have approved current Electricians License valid for the State in which the installation is being installed. Prior to commencement on site the Contractor shall validate the licence of all Electriciansto work on the project.

Communication Cabling Technicians installing and connecting SCS cabling shall be ACMA (Australian Communication & Media Authority) licensed and certified by Commscope, Siemon or R&M to carry out Cat6A Copper and Fibre Optical cabling installations and approved Woolworths SCS Contractor listed in the current SCS Specification.

3.8 COMPLIANCE TO AUSTRALIAN STANDARDS

All works, materials, installation, testing and commissioning shall comply with all relevant Codes, Standards and Regulatory Authorities having jurisdiction over the site. This will include but not be limited to the following Australian Standards in their latest release and amendments:

- AS/NZS 3000 Electrical Installations - Wiring Rules
- AS/NZS 3008 Electrical Installations – Selection of Cables
- AS/NZS 3760 In Service Test and Tag
- AS/NZS 3012 Electrical Installations – Construction and Demolition Sites
- AS/NZS 3017 Electrical Installations – Testing and Inspection Guidelines
- AS/NZS 2293.1 Emergency lighting and EXIT sign
- AS/NZS 3100 Approval and Test - Electrical Equipment
- AS/NZS 61000 Electromagnetic Compatibility
- AS/NZS 1680 Interior lighting
- AS/NZS 1158 Lighting for roads and public spaces
- AS/NZS 61439 Low-voltage switchgear and control gear assemblies
- NCC - BCA National Construction Code - Building Code of Australia

3.9 INSURANCE

The Builder will arrange insurance of all buildings and / or materials on site under a 'Contractor

All Risks' policy. The Contractor shall be responsible for ensuring his own plant and materials not secured or installed. The Contractor shall be responsible for all statutory insurance such as Workers Compensation (unlimited Common Law Cover) and Public Liability cover (not Less than \$20,000,000.00).

3.10 PATENT RIGHTS

The Contractor shall pay all Royalties due, and these shall be included as part of the Tender. The Contractor shall fully indemnify the Builder and Dan Murphy's against any action, claim or demands, costs or expenses arising from any infringement of letters patent, patent rights and design, trademarks or name, copyright or other protected means in respect of any plant, work, materials or thing, system or method arising out of the work or supplied by them or their Sub-Contractors.

3.11 PROTECTION OF PLANT MATERIALS & PROPERTY

The Contractor shall be entirely responsible for all apparatus, equipment and materials supplied or installed by themselves or Sub-Contractors in connection with the works.

Special care shall be taken to protect all parts in such a manner as may be necessary. In particular, they shall ensure that all open pipe ends or conduits are kept sealed whilst in storage or in the course of erection.

When working within existing store the Contractor shall cover the gondola, shelves, bench tops to prevent damage and contamination to the goods in the store.

3.12 SITE FOREMAN

While work is in progress, the Contractor shall keep on site a foreman empowered to receive and carry out instructions from the Builder to ensure the electricity hazards during construction are minimised.

3.13 VARIATIONS

No payment will be authorised for any extra work other than that authorised by means of all signed Contract Variations.

Should the Contractor receive an instruction from Endeavour Group, or their authorised agents, which he considers involves extra work, he shall immediately make a claim to the Builder for a Contract Variation Order. No work pursuant to this instruction shall be carried out until such an order is received.

Price variations shall be submitted in the first instance to Endeavour Group for checking. Full details of the variation shall be submitted and shall include a break-up description of the variation indicating labour and materials involved. Failure to comply with this requirement will result in the variation being rejected and the Contractor shall be held responsible for any delays caused as a result of delays in variation approvals.

3.14 TIME OF COMPLETION & LIQUIDATED DAMAGES

It shall be the Contractors sole responsibility to check with the Builder prior to signing the sub-contract and during the course of installation to ensure that his program of site works and work scheduling complies with the Builder's program of work on site. No extra will be allowed for failure to comply with this clause.

The Contractor shall schedule the work so that the following dates are achieved. It should be noted that they relate to the store handover date, which is some weeks prior to the store opening.

- All electrical work shall be completed by the date of handover except that associated with items to be installed under the fit-out contract.

- All wiring shall be completed one week before the store opening date.
- All facilities called for in this specification for Telephones, PA, CCTV, EAS, Satellite Music and Security shall be provided three weeks before the scheduled building handover.

The Contractor shall also be responsible for liquidated damages in the case of non- completion of the Contract to the extent as laid down by the Builder in his Contract.

3.15 DEFECTS AND CERTIFICATION OF PRACTICAL COMPLETION

Practical completion shall commence from the date on which the installation or part thereof placed into commercial operation and can be used by the Proprietor for the purpose for which it was intended.

Provided the works are commercially useable, minor items such as painting, final balancing, small commissioning defects shall not affect the issue of a Certificate of Practical Completion. However, monies to be paid at the date of practical completion shall not be certified until these minor works have been finalised. Documentation is not a minor item.

Provided Endeavour Group is satisfied, the Certification of Practical Completion will be issued and the warranty period will commence from the date of issue of Certification.

It shall be the Contractors responsibility when, in their opinion, the works are practically complete to give notice in writing to the Builder to this effect, with a copy to Endeavour Group.

On completion of the warranty period, a final list of outstanding defects will be issued. Retention sums will only be released when these outstanding defects have been remedied to the satisfaction of Endeavour Group.

The Contractor shall replace all defective works as instructed by the Engineer. Any defects not rectified within 4 weeks from the date of practical completion, shall be completed by alternative Contractors at the discretion of Endeavour Group. Costs associated with rectification works carried out by alternative contractors shall be deducted from the tender value.

3.16 WARRANTY

The warranty on electrical services includes design workmanship or materials for which the Contractor is responsible. If any defects become apparent under normal use of the Works, the Contractor shall remedy the defects when directed.

The warranty shall include the design of the electrical and communication services throughout the store. No variation will be given for rectification works due to non- compliance with the electrical specification and drawings.

The warranty on the completed installation shall run for twelve months from the date of store opening. This warranty shall include all items supplied.

The warranty on SCS cabling installation that shall run for minimum 15 years from the date of site certification as per approved Woolworths SCS system supplier requirements.

3.17 CUTTING & CHASING

All chasing and cutting for switches and power points etc., shall be the responsibility of the Contractor. The Contractor shall liaise with the Builder to ensure that all cutting and chasing is completed before final finish. All final finishes shall be carried out by the Builder.

The Contractor shall be solely liable for any chasing or cutting making good caused by the Contractor's mistakes or omissions. Chasing shall be carried out with a power saw unless required otherwise by the Builder. Holes in the masonry shall be cut with any approved masonry hole saw.

3.18 STORAGE

The Contractor shall be completely responsible for storage and protection of all plant, materials and equipment covered by this section of the work. For works associated with refurbishment of existing stores, the Contractor shall allow for his own storage space. The store will not provide storage space for the works.

3.19 TESTING & COMMISSIONING

The Contractor shall carry out all tests required by Endeavour Group to prove that all the electrical works comply with the requirements of this Specification.

Endeavour Group require that each item of electrical plant, RCD and equipment shall be tested prior to being energised as per AS/NZS 3760. Test and Tag all leads as necessary and record all test results in an approved on site hard copy "record log book" and in Excel format soft copy to the Engineer. The record book shall be included in the Operations and Maintenance Manual. Testing on completion shall conform to the above-defined Endeavour Group requirements.

The Contractor shall submit the completed SCS QA Certification and Acceptance Forms to the Engineer and Woolworths IT Network Services prior to Practical Completion. Test reports and certification for the SCS systems SHALL be put in the SCS cabinets within 3 weeks of hand-over of the completed installation by the Builder.

The Contractor shall pay for all expenditures incurred by Endeavour Group for re-inspection due to the Contractor failed to complete the SCS cabling systems and electrical installation after the date of Practical Completion.

3.20 OH&S REQUIREMENTS FOR CONSTRUCTION

It is the Contractor's responsibility to ensure that all portable equipment and leads used on site by the store, his employees and Sub-Contractors are tested and tagged in accordance with AS/NZS 3760 and all the applicable Workplace Occupational Health and Safety authorities' requirements.

The Contractor shall carry out the installation works strictly in accordance with relevant State OH&S Authority requirements.

The Contractor is not to work on a "live" switchboard. If the electrician must work under live condition, safety procedures and approval SHALL be obtained from Endeavour Group Engineer prior to commencement of the works.

The contractor shall ensure that circuit breaker lock-out devices are used when work on those specific circuits is carried out. The contractor shall provide circuit breaker lockout devices suitable for circuit breakers specified by Endeavour Group.

3.21 SITE ACCESS

During the construction period the Engineer and any consultant supervisors who have been nominated in writing to the Builder shall have free access to the site at all reasonable times.

The suppliers of equipment for phones, PA, E.A.S., Security, CCTV and Satellite Music shall be given free access to the site to allow them to carry out their contract responsibilities.

3.22 GENERAL PUTTING INTO SERVICE

The Contractor shall ensure that a licensed Electrician familiar with the project is on duty for the following two (2) working days: day before store opening and opening day.

The Contractor shall clean-up site and remove all surplus material and equipment prior to store opening.

3.23 CO-ORDINATION

The Contractor shall liaise with the Builder and Architect or their nominated representatives and all trades on site, as applicable, to ensure that the works are co-ordinated for the complete installation of equipment and material, this included co-ordinated working/construction drawings. The contractor shall be liable for any rectification works at the contractors cost and no additional cost to the Builder.

3.24 DRAWING SCHEDULE

Dan Murphy's Standard drawings shall be used as the basis and reference in the design and documentation of the Electrical and SCS data installation for a Dan Murphy's store. The Standard drawings shall not be used as construction drawings.

Use the information and details provided in the standard drawings to produce fully detailed drawings for the project. To enable drawings to be approved by Dan Murphy's without delay, use the symbols as per the Dan Murphy's standard drawings.

3.25 TEMPORARY ELECTRICAL PROVISIONS

Allow to provide temporary power boards and power outlets for construction purposes. All temporary power provided shall comply to health and safety requirements for construction sites.

Allow to supply, connect and later remove any temporary cables or outlets which may be required for temporary power connections to the existing Main Switchboard, Refrigeration, Mechanical DBs and to all distribution boards to keep the store operational at all times.

Provide temporary lighting to comply safety codes and as necessary to maintain lighting for construction works to be carried out. This includes temporary emergency and exit lighting.

Allow for an electrician to be stand-by during all excavation, demolition and cutting of existing surfaces as carried out by others in order that immediate remedial work can be carried out should any electrical works be damaged in the carry out of the above works. Allow for all costs for identifying and tracing of existing underground/in slab electrical services in the areas where cutting the floor slab and excavation is to be performed.

4. TECHNICAL REQUIREMENTS

4.1 EXTENT OF WORKS

The work covered by this Specification includes the supply, delivery to site, installation, connection, testing and maintenance of materials and equipment, all as specified for the electrical and SCS services.

Note that Dan Murphy's Standard layout drawings, control and departmental plans as appropriate are included in, and form part of this Specification.

The project includes, but is not limited to the following:

- 1) Dan Murphy's consumer mains from point of attachment to the terminals of the Dan Murphy's MSB.
- 2) Liaise and co-ordinate with Electricity Supply Distributor Authorities, Australian Communication Authority, and other relevant Authorities having jurisdiction over the site. Pay all fees as required by the Authorities.
- 3) Supply authority CT and tariff metering facilities.
- 4) Dan Murphy's MSB and distribution boards.
- 5) Sub-mains for general light and power, UPS, Generator, stand-by light and power, air conditioning and refrigeration boards, computer services and where required fire services including fire alarm and detection systems.
- 6) Complete earthing and neutral systems.
- 7) Circuit wiring, labelling and accessories for lighting, power and SCS systems.
- 8) Cable support systems including but not limited to catenary cable systems, cable ladders, cable trays, ducts and conduits.
- 9) Light fittings, emergency and exit lighting.
- 10) All internal and external car park lighting.
- 11) Stand-by lighting and power wiring and fittings.
- 12) Power to internally illuminated signs where supplied by others. This will apply to signs located both internal and external to the building.
- 13) Equipment wiring, plugs and connections.
- 14) All conduits and wall boxes for CCTV, Telephone, Public Address (PA), Satellite Music system, Electronic Article Surveillance (EAS) and Security systems.
- 15) Residual Current Devices (RCDs).
- 16) Bell systems.
- 17) Stand-by diesel generator, control panel GEN DB and wiring.
- 18) Telephone block cabling, mounting frame, direct line telephones and lead-in cable.
- 19) In-Store Communications Cabling systems, Structured Cabling System, Electronic Funds Transfer, Labour Management, RF, Scanning, Front and Back Office Computer Systems, include mounting frames, outlets, labelling and cabling.
- 20) UPS DB and wiring.
- 21) Control wiring from lighting relays and contactors to the Emerson CPC Energy Management System (EMS).
- 22) MATV system.
- 23) Mobile network 'Yagi' antenna cabling.
- 24) NBN services relocation.
- 25) 'As installed' drawings, log books, operation and maintenance manuals.
- 26) Testing and commissioning.
- 27) Remove and legally dispose of all existing redundant electrical services.
- 28) Other minor works as required.

The Contractor shall provide all materials and equipment and perform all work necessary for the complete and satisfactory operation of the whole of the electrical and in-store communication cabling installation, except where specifically excluded in the Specification.

4.2 SUPPLY

The supply shall be 415 volts, +6% & -10% 3-phase, 50 Hertz, 4 wires from the local Electricity Supply Authority. The earthing system shall be as determined by the local Supply Authority.

The Contractor shall advise Dan Murphy's prior to handover if there are excessive voltage fluctuations or electromagnetic interference problems from the source of supply.

Note: The quality and construction of the site MSB supplying the Dan Murphy's MSB shall not be less than the requirements for the Dan Murphy's MSB.

4.3 BALANCING OF ELECTRICAL INSTALLATION

The Contractor shall ensure that the whole of the electrical installation is balanced over the three phases to the satisfaction of the Supply Authority, AS/NZS 3000 and Endeavour Group Engineer. This shall take into consideration the single phase load of DB-Gen and DB-UPS.

4.4 VOLTAGE DROP

The Contractor shall ensure that all conductors installed are sized in strict accordance with the respective voltage drop rules and earth-loop impedance requirements, as stated in the AS/NZS 3000 Wiring Rules and this Specification.

The Dan Murphy's consumer mains and submains to each distribution board shall be sized in accordance with the loads.

The voltage drop between the point of supply and any point in the electrical installation shall not exceed 5% of the nominal supply voltage for a store that has a shared substation (e.g. store is part of a shopping complex), and 7% where there is a dedicated substation (e.g. for a stand-alone store).

Completed calculations showing the sizing of cable and voltage drop shall be submitted to the Engineer for approval.

4.5 TARIFF METERING

For new stand-alone stores and major refurbishments, the contractor shall arrange all details, access, parts, cables fixing brackets, cable paths, penetrations and all other requirements with the supply authority for the supply of tariff meters on the Proprietor's behalf and shall make all necessary provisions, including mounting facilities, junction boxes etc., as required by the Supply Authority. Meters shall be located adjacent to the Dan Murphy's MSB unless otherwise instructed.

The Contractor shall liaise with supply authority and Yurika (previously known as Metering Dynamics) for the installation of the revenue 'smart meter'. Direct metered consumer mains shall be provided for Dan Murphy's. Dan Murphy's **shall not** be issued with accounts based upon a sub-meter or an embedded network arrangement.

Note that the Builder is responsible for the cost of light, power, gas and other services provided by public authorities up until the handover date.

The Contractor shall assist the Builder to transfer all utilities accounts into Endeavour name by completing and submitting to Energetics (Endeavour/Woolworths billing management agent) the Utilities Account Setup Form included in the appendices section. This form shall be submitted at least eight (8) weeks prior to the handover date.

4.6 EARTHING

The earthing system shall be in accordance with the Statutory and Supply Authority requirements.

The earthing system for the installation is the MEN as detailed in AS/NZS 3000 and the Supply Authority requirements.

Submain and final subcircuits shall be earthed in accordance with AS/NZS 3000 and the

Supply Authority requirements.

Earth electrodes shall consist of copper or sheathed rods not less than 16mm diameter driven to a depth of not less than 1800 metre to reach the permanent moisture level. Unless disallowed by the Supply Authority, the footing shall be used as an electrode in addition to the above. The earthing conductor shall be connected to the reinforcing steel of the footing and the driven electrode.

All metalwork of electrical equipment, cable trays, cable ladder trays, conduit, metal checkouts cable ducts and the like for both electrical and data systems, shall be connected to the earth in an approved manner.

All cable reticulation originating from the switchboards shall be earthed at the switchboards by approved means, such as earth clamp and earth wire to the earth bar in the switchboards.

All earth cables at accessories, etc, shall be bonded together. Bonding shall be via sweating, crimp lug or other approved methods which is independent of the accessory cabling fixing method.

For each of the SCS BD and FD data cabinets, supply and install:

- A 6mm² Protective Earth to each cabinet, connected to cabinet earth lug, wired directly to the nearest switchboard.
- For BD cabinets, a Communications Earth Terminal (CET) installed adjacent to the electrical distribution board.
- A 12-way (minimum) Earth Bar with screw terminals within the cabinet, mounted to the vertical tray, to allow for patch panel earthing. A 6mm² Protective Earth shall be installed from the Earth Bar to cabinet lug.
- An individual 2.5mm² Protective Earth for each CAT6A patch panel connected to the Earth Bar.

Refer SCS Specification for further information on earthing requirements of SCS data cabinets.

4.7 CONSUMER MAINS & SUBMAINS

4.7.1 CONSUMERS MAINS

Consumers mains to the Dan Murphy's MSB shall have neutral conductors of the same size and number as the active conductors. All consumer mains cable terminations (both ends) shall be included in this contract. All consumer mains shall be insulated and sheathed copper cables.

For stores located within shopping centres, the store installation shall be regarded as a separate installation with the consumer terminals at the point of attachment. The MSB shall be fed from the un-metered tenancy terminals at the site MSB. All necessary provisions shall be made on this basis. No other areas of the centre shall be fed from this installation.

The MSB shall not be regarded as carrying essential or fire services. A separate fire rated sub-main shall be provided from the essential section of the site MSB to a separate essential services switchboard located in the Dan Murphy's store switch room.

The Consumers mains shall be sized to provide a load based on the calculated maximum demand (table C2 of AS/NZS 3000) times 1.25 or **300 Amps per phase** (whichever is greater) with due regard to voltage drops as specified and de-rating factors.

Submit completed calculations showing the sizing of all cables and the respective voltage drops, at the specified ratings, to the Engineer for information. Cables which do not conform to the above criteria will be rejected.

Where required by the National Construction Code/Building Code of Australia, consumer

mains shall be protected by enclosures having an FRL of not less than 120/120/120.

MIMS copper cables, Radox or Fireguard cables supported on cable tray can be used when essential services is required.

Consumers mains cables terminated at the Dan Murphy's MSB shall be fully shrouded with appropriate PVC insulation.

4.7.2 SUBMAINS

The submains shall be copper cables sized with due regard to the specified voltage drops and all de-rating factors.

Submit completed calculations showing the sizing of all cables and the respective voltage drops, at the specified ratings, to the Engineer for information. Cables which do not conform to the above criteria will be rejected.

4.7.3 UNDERGROUND INSTALLATION

All excavation, trenching, back filling, concrete draw-in pits, underground HD-UPVC pipes and fittings shall be supplied and installed by the Contractor. Cables shall not be direct buried. Conduits and Draw-in pits shall be sized so that cables one size larger can be drawn in if required.

4.7.4 RETICULATION OF CONSUMERS MAINS, SUBMAINS & TELEPHONE BLOCK CABLING

The site or tenancy consumer mains, Dan Murphy's consumer mains, submains and telephone block cabling shall not be underground within the Dan Murphy's tenancy. Site or tenancy consumer mains shall be external to the Dan Murphy's tenancy. Dan Murphy's consumer mains and submains shall be mounted on cable ladder at high level within the Dan Murphy's tenancy.

4.8 STORE MAIN SWITCHBOARD

4.8.1 GENERAL REQUIREMENTS

The requirements of this section can be met by the use of a standard Dan Murphy's pre-approved switchboard available from the approved switchboard manufacturers listed in this Specification. Workshop drawings shall still be provided for review, comment and approval by Endeavour Group Engineer.

Switchboards manufactured by a non-approved manufacturer will be subjected to a detail and lengthy testing, type test certification and approval procedures to the satisfaction of Endeavour Group Electrical Engineer. All switchboards without prior approval will be rejected.

The store MSB shall NOT be located under any water pipes, roof gutters and fire sprinkler head, so that water would not be impinge on the MSB. Liaise and co-ordinate with the Builder, Hydraulic and Sprinkler Consultants/ Contractors.

4.8.2 DRAWINGS

The workshop drawings shall be submitted for approval prior to commencement of manufacture, at least 14 days shall be allowed for these drawings to be returned from the date received by Endeavour Group Engineer.

Any comments noted on the drawings that are subject for approval shall be agreed to and then amended drawings with the comments incorporated re-submitted for final approval.

Delays that may arise through drawings not being available or late in submission shall be the responsibility of the Contractor. MSB manufactured without prior approval shall be

rejected.

The MSB shall be constructed as per the standard drawings and specification.

Type test certificates are not required if standard Dan Murphy's pre-approved switchboards are supplied by the approved switchboard manufacturers.

The Contractor shall submit the workshop drawings to the Supply Authority for approval when required by the local jurisdiction.

The Engineer is not to be regarded as the checking agent. Approvals for drawings will be given in principle only and without prejudice to the responsibility of the Contractor for the proper co-ordination, installation and operation of the board in accordance with the requirements of the specification and drawings.

4.8.3 INSPECTION AND TESTING

At all reasonable times, access to the place or places where manufactured or assembly is being carried out shall be given to approved person, for the safe and convenient supervision, examination and testing of any work or materials for the contract.

Notwithstanding any other tests, the MSB shall be subject to and shall pass on site all tests required by the Supply Authority.

4.8.4 DIAGRAM

The Contractor shall supply an as-installed single line diagram of the site MSB, Dan Murphy's MSB, and distribution switchboards, indicating dimensions, materials and design rating of incoming and outgoing connections, cable sizes, C.T. ratio etc. A laminated electrical distribution system schematic diagram shall be wall mounted in the switch room (minimum size to be A1).

4.8.5 PARTICULAR REQUIREMENT

In particular the MSB shall comply with AS/NZS 61439.1-2016 low voltage switchgear control gear assemblies for voltages up to 1000 V.A.C. and having the following characteristics:

- Indoor enclosed or cubicle type
- Form 2b construction to AS/NZS 61439.1-2016 for the MSB and Form 1 for the distribution sections.
- Rated supply voltage: 415V AC. Rated insulation voltage: 600V AC.
- Rated diversity factor as per AS/NZS 61439.1-2016.
- Rated short time withstand current: 25kA for 1 second.
- Busbars rated for 300A (minimum).
- Main switch circuit breaker rated at 300A (minimum).
- Degree of Protection: IP42 as per AS 60529-2004
- Safety measure shall be by earthing and by mechanical means.
- All equipment on the board shall be mechanically fixed.
- Separate neutral and earth bars sharing sufficient number and size of terminals for each circuit.
- Minimum IP54 protection to external switchboards.
- Hinged lockable door – CL001.
- Colour – glossy orange to AS 2700.

4.8.6 CONSTRUCTION REQUIREMENTS

The MSB shall comply in general with the requirements of this clause. The overall size of the MSB shall be such that it will fit into the space provided, making due allowance for all clearances under the AS/NZS 3000 Wiring Rules and the supply authorities service and

installation rules. The MSB shall be floor mounted comprising of free standing, folded sheet metal cubicles. Generally the MSB shall be constructed for top and bottom entry of all cables. Side entry of cables is strictly prohibited. All cable entries shall be sealed to maintain effective dust proofing of the MSB.

After installation, all access for cabling and maintenance will be from the front only. The MSB shall incorporate a lighting and power distribution section. These sections shall be physically segregated from the rest of the MSB.

The overall cubicle structure shall be fabricated from first quality, minimum 2mm gauge, cold reduced, bright, low carbon steel sheet to AS/NZS 1595.

The base shall be 75mm x 40mm steel channel. The base channel shall form a continuous box section around the base of the MSB, there shall be no openings made in this base, such as sometimes used for slinging. The base shall be bolted to the cubicle for easy access into the main switch room. All material necessary for reassembly shall be provided.

Removable front panel shall be dished. Where a panel exceeds 1 sq. meter in area, or if it may need to be removed frequently for access, it shall be hinged and equipped as a door.

Doors and escutcheon panels shall be stiffened and provided with chrome plated lift off pintle type non-ferrous door hinges. Door handles shall be chrome plated and incorporate a barrel type locking mechanism (each with keys - all keys for the store to be the same).

Escutcheon panels shall be secured via acorn nuts.

Door handles shall also have an adjustment on the shaft to increase sealing pressure when and as required.

All dished panels and doors shall be provided with concealed type gaskets of neoprene skinned sponge rubber, retained within a steel channel section, spot welded around the complete perimeter of the panel or door to prevent lateral movement of the gasket. Gaskets shall be proud of the panel or door by at least 3mm to provide effective sealing.

Provision shall be made for lifting complete MSB sections. Eye bolts shall not be used where they will be subject to shear stress.

There shall be adequate provision for incoming and outgoing cables with provision for glands as required.

Provision shall be made for suitable fixing of all outgoing cables within the cable compartment. This shall be continued in the form of a cable tray or approved cable cleats at no more than 150mm centres. Cabling space shall be such that no cable is bent with a bending radius less than 5 times its diameter.

Where both MIMS and PVC sheathed cables are used, the cable arrangements will ensure that the two types of cable are adequately separated.

Where spare space is to be left for future circuit breaker units, suitable holes will be drilled in the supply busbars and insulation barriers for the necessary line connections.

All hardware such as bolts, nuts, screws, washers, etc. shall be heavily cadmium plated. All handles and hinges on front panels shall be bright chrome plated. The MSB shall be securely fixed to the floor.

4.8.7 SWITCHBOARD BUSBARS

The busbars shall be of adequate cross section to meet the requirements of AS/NZS 61439.1-2016. Busbars shall be made of hard drawn high conductivity copper and be sized to ensure that the temperature rise of busbars and connection at the rating specified

does not exceed 70°C above an ambient temperature of 35°C. Busbars shall be identified by minimum 25mm wide heat resistant colour bands fixed by same colour cable tie neatly and permanently located at 500mm intervals and at appropriate points to distinguish between the phases.

Busbar sections shall be cleaned prior to coating as below. All joints shall be dressed flat, polished and coated with a thin layer of a corrosion-resisting compound prior to assembly.

Busbars shall be supported on approved insulating material.

Busbars shall be fitted with links so that current transformers may be readily removed whenever necessary.

Busbars in the connection chambers and the CT chamber shall be covered with approved PVC insulation tape and/or sleeving throughout their entire length.

Connections from circuit breakers to main busbars shall be as short as possible and rigid. Cables are not acceptable for internal connections on either side of circuit breaker units. A neutral bar of similar size and rating as the active busbars shall be provided.

When more than one cable per phase is run in any mains or submains, each cable shall terminate at a separate stud or bolted assembly. Alternatively, two cables may be connected to a busbar by common bolts, but in such case, two bolts, passing through both lugs shall be used, with the palm of each lug making contact with the busbar.

Where outgoing terminals are in a common cabling zone, the MSB design shall incorporate a substantial mechanical shroud over each set of terminals.

A full length earthing busbar shall be mounted in the MSB in an approved location for the connection of the low voltage earthing conductor.

If the M.E.N. system of earthing is employed, then the earth bar shall be bonded to the neutral bar, in accordance with the requirements of the supply authority.

The metal frames of MSB cubicles and equipment shall be effectively bonded to the earth busbar. For purpose of withstanding thermal stresses due to fault currents, active neutral and earth busbars shall be sized in accordance with AS/NZ 61439.

4.8.8 CIRCUIT BREAKERS

All circuit breakers shall comply with AS/NZS IEC 60947 and shall be of Terasaki manufacture Tembreak electronic type, or Schneider Merlin Gerin NS system type. All circuit breakers shall have a lock out capability.

4.8.9 FUSES AND FUSE BASES

Fuses shall comply with AS/NZS 60269 and shall be suitable for fault level of the installation and shall discriminate properly with the protective equipment. Let through energy and peak current cut-off shall suit the protective equipment.

All fuses shall be H.R.C. fuse links or DIN type. All fuse bases shall be fully shrouded.

Three spare fuse links for each size of fuse used in the MSB shall be provided. They shall be mounted either in a separate fuse case, wall mounted in the switch room or in a fuse rack behind a front door on the MSB. Permanent labels shall show the type and rating of fuses provided. An external label shall indicate where these fuse links are located.

4.8.10 METERING FACILITIES FOR SUPPLY AUTHORITY

The Contractor shall make all metering provisions in the MSB to comply with the Supply Authorities requirements and arrange for the Supply Authorities current transformers to be

provided and installed within the busbar system to their approval.

4.8.11 WIRING

All wiring shall be arranged in a regular manner with bends set at 90° and securely held in position with approved saddles, insulating bushes being used where necessary.

All secondary wiring and meter wiring of the MSB shall be carried out in PVC type V-75 insulated switchboard cable, minimum 2.5 square mm shall be used. All such wiring shall be of similar colours to those of the respective busbars, etc., to which connections are made. The terminations shall be made with compression type lugs and terminated on approved terminals.

Wiring shall be carried out in such a way as to make circuits and connections easily traceable. Cable marking ferrules or similar shall be used at each termination. Terminals shall be designed in an approved manner.

All terminals shall be fitted with flat washers and securely fixed with lock nuts or spring washers.

4.8.12 CABLE ENTRIES

All cable entries shall be sealed to achieve minimum IP42 rating. Provision shall be made for top and bottom entry of all cables. Side entry of cables shall not be permitted. Where cables enter the board, mains and submains cables shall run through glands.

Type and size of submains cables shall be indicated on the single line diagram and provision shall be made for the adequate spacing and support of these cables.

All MSB openings shall be sealed immediately after the wiring works have been completed. All glands for cable terminations shall be provided.

4.8.13 LABELS

The labels shall be machine engraved on Traffolyte plates screw fixed with an approved adhesive.

The lettering and numbering shall be engraved in Black Text on a White Background colour and shall be 25mm minimum height for the designation of the MSB, 12mm minimum height for the distribution boards and 6mm minimum size for the designation of equipment.

As a minimum, the following information shall be shown on the labels:

- Manufacturer's name, address and phone number;
- Serial Number
- Type Test Certificate Numbers
- AS/NZS 61439 type details
- Dimensions and weight
- Fault level and degree of protection;
- Type and size of consumer mains and submains amp rating;
- Current rating of switchgear;
- Date of manufacture

4.8.14 FINISH

All metal work shall be thoroughly cleaned and free from scale, sand, rust or grease, deformation, dents, cracks and scratches prior to undercoating and spraying.

The exterior and interior of the MSB shall be given a minimum of one undercoat and two

final coats of spraying enamel paint, interior - white, exterior - electrical orange.

The MSB shall be vacuum cleaned internally.

4.9 DISTRIBUTION BOARDS

Supply and install distribution boards DB-Generator and DB-UPS.

Distribution boards for Light and Power services shall be incorporated into the store MSB.

Distribution boards shall not be located in an emergency egress path as per the NCC-BCA.

Any existing DBs shall be removed together with all associated sub-circuits and submains.

4.9.1 CONSTRUCTION

Distribution Boards (DB's) shall comply with AS/NZS 61439.1-2016 with the same characteristics as the MSB except for the following variations:

- Form 1
- Rated input current - minimum 125% of calculated maximum load.
- Rated short time withstand current 20kA.
- Degree of Protection: IP42 as per AS 60529-2004
- Colour – glossy orange to AS 2700.
- Separate neutral and earth bars sharing sufficient number and size of terminals for each circuit.

All switchboards shall be surface or flush mounted as nominated on the drawings. Depth of surface mounted boards shall be 200mm and recessed switchboards shall not stand proud of walls by more than 50mm. Board fixings shall be through the back or floor of the board.

Escutcheons shall have individual spaces punched for 3 phase circuit breakers. Spare spaces shall be filled with pole fillers. Where necessary an enclosure of sheet metal, same colour and finish as the switchboard, between the floor and the base of the board shall be provided to conceal bottom entry wiring. All cable entries shall be dustproof.

A neutral link and earth bar shall be provided numbered consecutively for every circuit breaker pole location.

A typed circuit schedule shall be provided and installed on the inside of the door of the distribution board and shall be completed by the Contractor to indicate the following:

- Distribution board designation or circuit number
- Neutral connection number
- Rating of circuit breaker/ RCD
- Size of cable
- Details of installing contractor.
- Date of installation

4.9.2 ARRANGEMENT

The circuit breaker shall have an interrupting capacity of a minimum 6kA and above. All circuit breakers shall have a lock out capability. Both lighting and power circuits shall be minimum 20A rating.

A three phase insulated busbar assembly shall be fitted. Busbars shall be of high conductivity copper. Unused busbar connections shall be suitably sleeved.

Input connections to the busbar shall be by means of a bolted connection to a lug on the

cable end. Tunnel type terminations are not acceptable. Use minimum standard 225 Amp busbar assembly with the busbar termination suitable for a bolted lug connection. The bolted connection shall be insulated with heat-shrink tubing.

The circuit breakers are to be mounted continuously on the mounting chassis.

Circuit breakers shall be mounted so that the operating toggles are between 250mm and 1800mm above finished floor levels.

Circuit breakers controlling lighting circuits shall be grouped and connected to separate chassis for the energy management system.

Circuit breakers controlling final sub-circuits nominated as "separately maintained" shall be fitted with lock-on attachments, be labelled "DO NOT TURN OFF" and be grouped on their respective switchboards. The grouping arrangement preferred places normal circuit breakers at one end of the busbar assembly with the maintained units grouped at the other. The spaces between can then be used for the expansion of either group.

Spare spaces shall be provided for the future accommodation of a 20% increase in number of circuit breakers in each section and the panels shall be fitted with the necessary studs and busbar connections to facilitate fitting additional circuit breakers without the disturbance to the existing installation.

All power circuits supplying socket outlets, permanent connection for electrical equipment and lighting circuits shall be protected by Residual Current Device (RCD). A list of circuits requiring these devices is shown on the electrical single line diagrams.

The RCD shall be a single pole unit of the same brand and type as the circuit breakers. The RCD shall comply with AS/NZS 3190. For 3-phase loads, the RCD shall be an integrated 4 or 6 pole unit.

Each DB shall include adequate wiring space. The arrangement shall allow for the ready installation of new cables or rearrangement of existing cables with a minimal requirement for de-powering. The bunching of cables shall be minimised so that the heat build-up does not occur.

The distribution board, individual equipment thereon, circuits, and lighting and power sections shall be described and/or identified with labels as specified in the MSB section of this specification.

All active, neutral and earth circuits shall be identifiable by means of cable ferrules, the number on the ferrule corresponding to the circuit number of the cable. The neutral and earth wires shall be connected to the respective bars in positions having the same number as-the circuit number.

On every switchboard the load shall be balanced as evenly as possible across the three phases.

4.9.3 TERMINATIONS

In all switchboards, all cable terminations shall be made using compression type lugs on all cable ends and using approved bolted terminals. Cable entries into switchboards shall be by means of cable glands, or similar approved arrangement, which maintains the dust proofing of the switchboard.

Throughout the whole installation, connections to equipment such as contactors, relays, time switches, etc. shall be made by use of compression lugs. The lug shall only be installed with a ratchet type crimping tool which ensures a full crimp with every operation. Insulation shall only be removed just prior to the termination being made.

Provide cable circuit wrap labels at the switchboards or switch panels where there are

more than one cable terminations.

Termination of all cables shall be in strict accordance with the cable manufacturer's recommendations and procedures.

All live, neutral and earth sub-circuit cabling terminations within switchboards shall be labelled.

4.10 CASCADING AND DISCRIMINATION

Protection devices shall be selected to provide cascading and discrimination between upstream and downstream devices. It shall be arranged so that only the protection device immediately upstream of the fault shall operate to clear the fault.

Shop drawings shall show details of protection settings from Supply Authority protective device through to final sub-circuit protective device.

As built manuals shall contain plotted curves demonstrating discrimination and final settings of all adjustable protective devices. This information shall be shown on the wall mounted single line diagrams.

4.11 CABLING SUPPORT SYSTEM

Two (2) cable support systems used for cable reticulation shall be as follows:

(a) Primary Pathway

Main horizontal reticulation run **within ceiling** space consists of overhead services duct and steel cable basket for Data, PA, CCTV and security, and cable tray/ladder (General Power and UPS power). Note, cable baskets shall only be used in trading areas with false ceiling (e.g. T-bar grid), **otherwise cable trays and metal ducts shall be used with exposed ceiling**.

(b) Secondary Pathway

Consists of final reticulation from Primary Pathway to accessories and equipment. This is provided via service columns, catenary wire, PVC or steel conduit.

The purpose of the cable support systems is to maintain required segregation between the various cable types in accordance with AS/NZS 3000 and A.C.M.A. requirements in order to maintain the integrity of the signal on the SCS cables, i.e. to minimise the amount of electrical interference imposed on the cables.

4.11.1 GENERAL

Separate support systems shall be used to reticulate Security/CCTV, PA, SCS, UPS power and general power cables.

At all times within checkout furniture, equipment cabinets, etc, UPS power and general power cables shall maintain minimum clearances where they are not completely enclosed by cable tray, cable ducts or rigid and flexible PVC/steel conduit. The minimum clearance for these cables is 300mm.

Minimum separations between SCS cabling, General power and UPS power cables are to be maintained in accordance with AS/ACIF SOO9.

Conduits shall be securely fixed to building members, they shall generally be run square to the building perimeters.

Under no circumstances are ceiling grid hangers to be used as a method of supporting services.

Holes cut in the sides of metal ducts for cable entry shall be machine cut and bushed accordingly.

4.11.2 SERVICE COLUMNS

Service columns shall reticulate data, UPS and general power cables to the accessories. The service columns shall be used in areas as indicated in the drawings. Flexible conduit shall interconnect all cabling between the Primary cable support system and the outlets via the service columns.

Within the floor cabinets such as the service desk and checkout cabinets, cables shall be surface run. General, UPS and SCS data cables shall be run in flexible corrugated PVC conduit.

4.11.3 METAL DUCTING SYSTEM

A three (3) channel wall duct system shall be supplied and installed for the installation of general power, UPS power, data cabling and outlets as indicated in the drawings.

4.12 CONDUITS & FITTINGS

4.12.1 GENERAL

Generally, rigid UPVC conduit shall be used throughout, except where otherwise specified in the Specification. The size of the conduits shall be determined by the number and size of cables plus an extra 100% spare capacity. For multiple cables in conduit, the ratio of the sum of the effective cross-sectional areas of the cables to the minimum internal cross-sectional area of the conduit shall not exceed 0.4.

Conduits and fittings shall comply with AS/NZS 2053.1 Conduits and fittings for electrical installations. Conduits smaller than 20 mm diameter shall not be used except for PA, Security and fire alarm systems where 16mm diameter will be accepted.

The correct sizes of internal springs shall be inserted in UPVC conduit before making normal cold sets and bends.

Galvanised screwed conduit and fittings and not rigid UPVC conduit and fittings shall be used in the following locations:

Where exposed to mechanical damage.

Where subject to ambient or contact temperatures exceeding 60°C.

4.12.2 CONDUITS IN CONCRETE

Where UPVC conduit is embedded in concrete which is vibrated after pouring, or where conduits may be subjected to heavy traffic prior to pour, the Contractor shall in both cases, provide constant supervision by a responsible person to ensure that conduit runs are not damaged.

Where conduit is damaged or bumped during installation, the affected section shall be cut and a new piece installed.

The Contractor shall be responsible for such damage and shall make good at their own cost. Curves in conduits shall not have a radius less than standard long sweep bends.

All conduits entering junction boxes etc. shall be tied 300mm away from the box, thus ensuring at least 300mm straight run of conduit into the box.

Sealing caps shall be placed on all conduits before pouring is commenced, thus ensuring that no water or slurry enters the conduit. Conduits shall be swabbed or blown clear before wiring is installed.

All conduits in slab shall be installed above the bottom layer of reinforcement and securely tied in place, boxes firmly fixed to form ply and be separated from other conduits in a slab by a distance equal to the diameter of the conduit. Conduits shall be turned out at the slab and be left protruding at least 25mm above the finished floor level and this up-stand in the conduits shall be maintained.

Every care shall be taken to eliminate the possibility of water entering the floor conduit system.

4.12.3 CONDUIT INSTALLATION

Wherever possible conduits shall be concealed from view by burying them in concrete slabs, chasing in walls, installing in cavities etc. Chases in walls shall be vertical or horizontal.

Where conduit is run in cavity walls exposed to the weather care shall be taken to ensure that a wet situation is not created between the external skin and the internal skin of the wall.

Conduits shall be run at all times in a manner which will not necessitate penetration of the damp courses or permit the entry of moisture to any portion of the building.

Conduits 40mm in diameter or larger shall be sealed with a readily removable inert material to prevent the passage of vermin.

Conduits provided for other contractors shall be blown clear of debris and fitted with a galvanised draw wire.

Expansion coupling shall be used for each 6800 mm conduit run or part thereof.

Flexible conduit, either metallic or UPVC shall be used to connect all permanently connected appliances and motors.

Conduits shall terminate at switch and wall outlets in flush wall boxes and at ceiling outlets in deep junction boxes, unless otherwise specified.

All conduits shall be installed in such a manner as to allow easy draw in of cables.

All spare conduit and conduit for future wiring shall be complete with draw wire and be labelled to identify its purpose.

Draw in boxes shall be used where necessary to enable its purpose. Draw in boxes shall be used where necessary to enable drawing in of long runs of cables.

UPVC conduits shall be Low Density Grey. Joints between UPVC conduits and accessories shall use PVC jointing cement. Joints between UPVC conduits and steel enclosures shall be effected using threaded terminations and locknuts.

Conduits shall be in long lengths, straight, smooth, and free from dags, burrs and sharp edges. Off-cuts shall not be used to fabricate longer lengths of conduit. Conduits shall be set wherever possible in order to minimise the number of joints.

Bends in steel conduit shall be made by a proprietary-bending machine. Bends shall be of large radii and shall be correctly formed taking due regard to allowing easy draw-in of cable installation. Conduit sets showing evidence of flats and burrs shall be rejected.

Draw-In boxes shall be used where necessary to enable drawing in of long runs of cable. Terminate all conduits using threaded steel terminations, locknuts and washers.

All steel/galvanised conduits, flexible steel conduits and metal ducts shall be electrically

bonded to earth and connected to a Protective Earth at the nearest electrical distribution board with a maximum resistance from any point on the system to earth of 2 Ohms.

The flexible steel conduit shall have an outer PVC sheathing. All connections shall be made via locknuts and washers.

Maintain electrical and mechanical continuity in all steel conduit systems.

The following table sets out the cable (and conduit) installation for the various wall constructions. This is applicable to all cable types.

Wall Construction	Installation Requirements
Rendered block partition	Flush wall box - conduit chased into wall.
Face block partition or wall (hollow block)	Flush wall box - conduit concealed in hollow blocks, prior to filling with concrete.
Face brick external cavity wall	Flush wall box - conduit run in cavity.
Stud partition	For Power -D or angle bracket (if adjacent to framing member). For SCS - Flush wall box - conduit run in cavity.
Cool-room insulation wall	Flush wall box - conduit surface mounted on wall

4.12.4 METAL CABLE DUCT

Metal cable duct or trough with clip on or screw fixed covers shall be galvanised steel manufactured from minimum 1.6 mm thick sheet steel and shall be fixed to relevant ceiling slabs and walls on robust and substantial brackets at intervals not exceeding 1200mm.

The size of the ducts shall be determined by the number and size of cables plus an extra 100% spare capacity. For multiple cables in ducts, the ratio of the sum of the effective cross-sectional areas of the cables to the minimum internal cross-sectional area of the duct shall not exceed 0.4.

Where ducts change their direction, sufficient bending radius shall be provided to allow easy installation of cables.

Any change in direction or joining of ducts shall be done using nuts and bolt. Pop rivets are not acceptable.

All ducts shall be labelled as to their use. Holes in ducts for the passage of cables shall be neatly cut and bushed. Provide bushes, screwed coupling and adaptors for cables branching out to corrugated flexible UPVC conduits.

4.13 CABLE TRAY & CABLE LADDER

All cabling shall be installed on tray and/or cable ladder and/or catenary wire.

Cable tray shall be used for final sub-circuit wiring. Cable ladder shall be used for consumer mains, submains and cables larger than 25mm². Catenary wire for horizontal cabling can be used for final sub-circuit wiring provided that no more than six (6) individual cables are supported by each catenary wire.

Where mains and/or submains are to terminate onto switchboards from above they shall be supported on overhead cable ladder.

Where mains or submains are carried on cable ladder, the contractor shall supply and install all necessary hangers etc., for cable tray and these will need to be of sufficient length to enable

the cable ladder to clear beams etc. without an unnecessary change of direction.

Where cable ladders and cable trays are used, wire type suspension systems are not permitted. This shall apply to Dan Murphy's consumers mains, submains and telecommunications lead-in cable. Threaded rods shall be used.

Mechanical protection shall be provided to cable trays and ladders when mounted at low level and in areas that are prone to mechanical damage. Specifically, vertical trays and ladders in back-of-house areas (e.g. offices, switchrooms, comms rooms) shall have mechanical protection to at least 1000mm from floor or to the underside of any wall mounted switchboards, and at least 4000mm from floor where trays or ladders rise vertically in stock and loading dock areas. The protection shall be of a form which does not de-rate the cable.

All groups of single core cables comprising three phase circuits shall be run in trefoil formation throughout the entirety of their route.

Where cables rise vertically, the contractor shall support these on cable cleats or clamps, the cable tray or ladder being securely fixed to holding brackets as specified herein.

Cable tray, cable ladder and catenary wire routes shall be checked to ensure that they do not clash with other services.

Where possible, cable support systems shall be installed in locations that provide the easiest access for future rewiring.

Switchboards and distribution boards shall not be used to support cable trays or cable ladders.

Where cable support systems are visible on the trading floor, they shall be painted to the same colour as the ceiling.

4.13.1 CABLE TRAY

Cable trays shall be manufactured from steel, hot dipped galvanised after fabrication with folded edge not less than 20 mm high and be of 1.6 mm thickness with punched slots. Minimum cable tray size shall be 150mm.

Fixing to underside of floor slabs or underside of roofs shall be via threaded rods of minimum M10 size. Supports shall be fixed at intervals not exceeding 1500mm.

Edges shall be folded with a radius. Slots shall be free of burrs and sharp edges on the side to which cables are installed.

Where the cable tray changes direction, sufficient bending radius shall be provided to allow easy installation of cables. The midway point of the arc of the change in direction shall be supported by a threaded rod.

Where cables leave the cable tray, plastic sleeves shall be provided on the metalwork.

Cables shall be supported with nylon ties at 1000mm centres for vertical runs and 2000mm centres for horizontal runs.

Cable tray shall be appropriately fixed on robust and substantial brackets fixed to walls.

Where this is not possible, suspension rods shall be provided, securely fixed to overhead supports, together with bracket arrangements to facilitate the support of the tray. Suspension rods shall be minimum 10 mm diameter mild steel.

Brackets or suspension supports shall be fixed at intervals not exceeding 1500mm.

Where trays penetrate fire walls or where required by Authorities, fire barriers and fire proofing of the tray shall be provided by the Contractor. The Multi-Diameter Rox Gland

M63 modules or similar should be used.

Holes in the tray and edges where cables pass over shall be sleeved.

4.13.2 CABLE LADDER

Cable ladder shall be sized to support the cables, which it is to carry plus 20% space.

It shall be hot dipped galvanised type with a minimum classification of medium duty. Bend, tees and similar accessories shall be factory fabricated shall also be hot dipped galvanised.

Cable ladder shall be supported from heavy duty cantilever brackets or suspension rod systems as appropriate, spaced in accordance with the manufacturer's recommendations and secured with hold down clamp.

The suspension rod system shall consist of 10 mm minimum hot dipped galvanised rods, nuts and a Unistrut support channel brackets or suspension supports shall be provided in accordance with the manufacturer's recommendation or every 3 metres whichever is the least.

4.13.3 CATENARY WIRE

Sub-circuits can be run on a catenary wire provided that it carries no more than six (6) cables. Cables on a catenary wire shall not open to view and shall be limited for use in ceiling space only.

The catenary wire shall be properly supported, not be supported on false ceiling suspension and not be used as an earthing conductor.

Catenary wires shall be tensioned via turnbuckles or U-bolts with half thread available for tensioning.

The catenary systems shall be constructed from stainless steel or coated galvanized cable and couplings.

4.14 WIRING AND CABLING

4.14.1 CABLES

All cable runs shall be installed using unbroken lengths of cable.

All wires and cables except where otherwise specified shall be type V75 thermoplastic insulated and thermoplastic sheathed, copper stranded cables of Australian manufacture.

All 3-phase cables to equipment and appliances shall be 4 core + earth, orange circular, V-90 insulated, PVC sheathed.

All cables installed through continuous rows of lighting shall be type V105 grade insulation.

Wiring associated with essential services such as fire sprinkler pumps, fans and fire alarm systems shall be fire rated type cables and completely segregated from other wiring.

The minimum size of conductors shall be as follows:

Lighting Circuits	2.5 square mm (7/67)
Socket outlets	2.5 square mm (7/67)
All other power circuits	2.5 square mm (7/67)
Control and thermal alarm circuits	2.5 square mm (7/67)

4.14.2 INSTALLATION

All wiring shall be installed using the loop-in system, joining of cables shall only be made at fittings or accessories. The use of connectors will not be permitted except where required by the AS/NZS 3000 Wiring Rules for the connection of heat resisting cables.

All circuits shall include a separate earth, which originates from the same distribution board as the circuit active conductors. All conductors in a conduit shall be drawn in at the one time and be capable of being easily withdrawn from the conduit if required. Particular care shall be taken with the installation of cables to avoid twisting. Wiring passing through walls, floors and areas where abrasion may occur shall be sleeved.

All wiring in which abrasions of the insulation occur will be condemned and shall be replaced by the Contractor at their own expense.

TPS cables shall not be installed where open to view, except when run in cable trays and only then in stockrooms and plant rooms.

Where approval has been given for TPS cables to be installed in locations open to view, they shall be run parallel to walls, ceilings, building members etc. and shall be fixed with clips at maximum 300 mm centres with a maximum of two cables per clip. Where fixing for clips is not available, TPS cables shall be enclosed in conduit or alternatively the clips shall be secured in soft wood battens.

Where TPS cables are installed in accessible locations concealed from view or above removable ceiling tiles they shall be secured to the roof framing, slab or softwood battens with clips, straps, clamps or saddles or catenary wire. Cables shall be supported at a maximum of 1200 mm spacing with minimum sag, so that they are held clear of ceiling tiles. The cables shall be secured to prevent any strain on the connections.

TPS cables shall not be run in locations where they cannot easily be withdrawn for rewiring purposes. Where TPS cables are installed in inaccessible locations such as cavities, stud partitions, non-removable false ceilings, etc. they shall not be clipped or secured. Where TPS cables are concealed within cement rendered wall or concrete slabs, the cables shall be enclosed in conduit.

TPS cables subject to mechanical damage shall be adequately protected.

Earth wires shall be so arranged so that the continuity of the earthing conductor is not broken if an accessory is removed. In particular, where an earth wire is looped into an accessory it shall be held together by crimping or other approved means prior to insertion in the accessory.

All TPS cables terminated onto the switchboard shall be neatly secured onto cable tray by nylon cable ties in bunches of six (6). Bunching of more than six (6) TPS cables shall not be permitted. In all cases, cable runs shall be neat and tidy and run square with the building.

Security of cable runs is important from the perspective of accidental and or malicious damage. Where cable is to be fed through masonry penetrations, penetrations shall be sleeved with UVC conduit with 20mm excess extending either side. Conduit ends shall be smooth finished to prevent abrasion to cables. Fire-Stopping (where appropriate) of all penetrations shall be performed prior to practical completion.

Cable access through any metallic opening shall be appropriately protected by manufactured grommets or bushings. Where continuous bushing is used, it shall be of appropriate gauge and length to ensure all edges of the opening are protected and shall be held in place by means of a suitable adhesive.

Any redundant cabling including from existing installations shall be removed from site.

4.14.3 COLOUR CODING

Conductors shall be uniformly colour coded throughout the installation using:

For multi-phase	- red, white, blue circuits for phases, black for neutral
For single phase	- red for active conductor, black for neutral and white for switch wire.
For D.C. wiring	- brown for positive conductor and grey for negative

Sheathing shall be colour coded throughout the installation by using:

Fire Service	- red
D.C. circuits	- grey
UPS circuits	- black
All other services	- white or orange

4.14.4 CIRCUITING

Circuiting of outlets shall be in accordance with the accompanying drawings and within the limits of the distribution board zones indicated. Also, where shown, switching to time controlled circuits, security lighting, corridors, stairs etc. shall be provided.

Where single phase switching is grouped under a multi-gang switch plate the use of more than one phase is prohibited.

4.15 ELECTRICAL ACCESSORIES

Fittings and accessories shall be of an approved manufacture and rating shall be selected to meet the requirements of the location and function. All single phase socket outlets shall have the earth pin located at the six o'clock position and shall be polarised as recommended in the Wiring Rules unless otherwise stated. Socket outlets, unless otherwise specified, shall have a minimum 10 Amp capacity rating. Accessories shall be flush mounted except where otherwise indicated. Generally, faceplates shall be minimum size 114mm x 70mm, in impact resistant white plastic (WE) and have smooth, flat surfaces.

Each socket outlet shall be labelled to provide ready identification of its circuit and the origin of its circuit. The outlets shall have a label window at the centre of the faceplates. Refer Clause "Labelling".

Outlets shall not be mounted over the junction between different wall finishes.

Socket outlets shall be provided to all electrical plant and equipment as shown on the Control Plan. The rating of the outlet shall be minimum 30% more than the full load rating of the total equipment loading.

Three phase socket outlets shall be recessed using the outlet manufacturers standard insulated flush plate.

Wall boxes shall be used, except in timber partitions and shall be set into face block work or coolroom insulation panel walls without damage to the wall finish. For all wall boxes not in use, the Contractor shall supply blank cover plates.

Light switches shall be installed in positions shown on the drawings, or as directed on site but a final check of all locations and door swings shall be made on site before the actual installation of the switches is commenced. All light switch mechanisms shall be rated at 20A.

Surface mounted fittings may be used where conduits are run on the surface.

4.15.1 SERVICE DESK & CHECKOUTS

High impact polycarbonate socket outlets shall be used. All socket outlets shall be surface

mounted on standard mounting blocks and located in concealed positions as indicated on standard detail drawings.

Metal checkouts shall be earthed where socket outlets are mounted.

4.15.2 LOADING DOCK, PLANT AND STOCK ROOMS

Light switches and socket outlets in the plant room, stock room and loading dock areas shall be IP56 type.

4.16 INSTALLATION OF EQUIPMENT

4.16.1 PERMANENTLY CONNECTED EQUIPMENT

Connect all items of permanently connected equipment where shown on plan. This includes those which will be supplied and installed by others.

Each item of equipment shall, unless otherwise specified, be supplied by a separate circuit from the distribution board and shall run via an isolating switch mounted on the wall adjacent to the item.

The isolating switch shall comply with the list elsewhere in the specification. Each circuit to equipment shall be of the type and rating shown on the drawing.

4.16.2 ROLLER SHUTTER DOORS

All roller shutter doors will be supplied and installed by others, motor starters and limit switches will also be supplied.

The Contractor shall supply and install all necessary sub-circuit wiring, install in position all control equipment for the satisfactory operation of the doors. Supply and install a suitable rated isolating switch adjacent to the motor starter.

All control circuits shall be 240V 50Hz. Motors can be either 240V single phase or 415V 3-phase 50 Hz depending on the size of roller doors, the Contractor shall confirm with the roller shutter door contractor on power requirements for each roller door, including those outlined in the following sections.

4.16.3 LOADING DOCK ROLLER SHUTTER

The Contractor shall liaise and co-ordinate with the Security Contractor so that the Stock Room Remote Arming Station (RAS) shall operate the opening of all roller doors. The electrical control mechanisms shall be interlocked to the Security Alarm Panel so that the "up" buttons for each shutter are inoperative under normal conditions. Entering the required code on the RAS in the Stock Room shall cause roller shutter control buttons to be activated for a specified period of time. This will normally be programmed for a period of three minutes but may be varied by instruction for the Endeavour Group Regional Loss Prevention Manager. The "close" buttons shall be operable at all times.

All works, cabling, terminations, etc to the roller shutter controls from the RAS and/or the Security Alarm Panels are the responsibility of the Security Contractor.

Supply and install all necessary sub-circuit wiring, contactors, relays, interlocks, etc. as required. Liaise and co-ordinate with the roller shutter contractor accordingly.

All controls shall be grouped together and installed adjacent to the door opening in the location as determined on site.

4.16.4 SHOP FRONT ROLLER SHUTTER DOORS

All roller shutter doors, motor starters and limit switches shall be supplied and installed by

others.

The Contractor shall supply and install all necessary subcircuit wiring, install in position all control equipment for the satisfactory operation of the doors. Supply and install a suitable rated isolating switch adjacent to the motor starter.

4.16.5 AUTOMATIC BIPARTING DOORS

The Contractor shall supply and install all wiring for automatic bi-parting doors.

The circuit to automatic bi-parting doors shall comprise two separate socket outlets mounted above the door head, with one controlled by an isolating switch mounted on the mullion at height of 2000 mm above floor level.

Miniature skirting outlets may be used in this application. One circuit per two door units shall be provided.

4.16.6 DOCK LEVELLERS & SCISSOR LIFTS

The Contractor shall supply and install all wiring for dock levellers including isolating switch near the dock leveller control panel and cabling for the termination to be carried out by dock leveller supplier.

Supply and install an interlock control system so that the dock leveller cannot operate whilst the roller shutter is closed. Liaise and co-ordinate with the dock leveller and roller shutter contractors.

4.17 POWER SUPPLY TO OTHER SERVICES AND SYSTEMS

These services and systems, provided by others, may include but are not limited to the following:

- Mechanical
- Refrigeration
- Fire Alarm
- Security Alarm
- CCTV
- Public Address
- Fridges
- Boiling Water Units and Hot Water Units
- Cleaner outlets
- Electronic Article Surveillance (EAS)
- Auto Entry Gates
- PA
- Satellite Music

The Contractor shall provide dedicated separate submains and sub-circuits to these services and systems as required. All cabling shall be rated to carry the continuous load requirements of the services and systems. Provide all accessories, cable, conduits, cable glands, hardware, socket outlets and permanent connections necessary to the services and systems as required. This shall include terminating submains onto the line side of the main circuit breaker as required.

4.18 LABELLING OF ACCESSORIES & EQUIPMENT

Provide 'Brother P-Touch Professional' (black text on white) labels for all socket outlets and switch plates. Labels shall be chemical resistant.

The labels shall indicate the distribution board and circuit number. The numbering shall follow the form DBM-nnn where: DBM defines the supply fed from the DB. M is sequential numeric 1-

9, and nnn is the circuit breaker number 001-999.

Provide a label schedule nominating wording, letter size and label size for all items requiring labels. Do not manufacture labels without approval of label schedule.

Sign writing on outlets shall not be accepted.

Labels shall be provided for all cable support systems located at change in direction, change in methods, at the start and end of runs and where cables enter or leave the cable support system. Labels shall be located to be visible from the position most likely for installing cables into the cable support system.

All SCS outlets shall be engraved traffolyte.

4.19 LIGHTING REQUIREMENTS

4.19.1 GENERAL

Supply and install new lighting in accordance with the drawings. The lighting design and installation shall comply with AS 1680.1.

The following are minimum average illuminance level requirements for various areas.

Area	Required Lux Levels	Orientation
Service, checkout	500	0.75m AFL on horizontal plane
Aisle and wall fixtures	1000 350	1000 AFL on vertical plane Floor level on horizontal plane
Walk-in coolroom	500	0.75m AFL level on horizontal plane
Offices	320	0.75m AFL level on horizontal plane
Loading Dock	240	0.75m AFL on horizontal plane
Stockroom	240	0.75m AFL on horizontal plane
Team Dining	240	0.75m AFL on horizontal plane
Team amenities	160	0.75m AFL on horizontal plane
Corridor, stairs	80	Floor level on horizontal plane

All luminaires shall be purchased from nominated lighting suppliers as indicated on lighting legend. All luminaires shall be installed complete with the light source and control gear.

All major components used in the fittings are to be of first grade quality and to be in accordance with AS/NZS 60598 "Luminaires - General requirements and tests".

Recessed luminaires shall be fitted with 1.5 metre length flexible cords and 3 pin plugs. The flexible cord shall be PVC sheathed, 3 core with 2.5 square mm conductors and shall comply with AS3191.

Where light fittings installed on Ezystrut cable ladders, flexible cords and plugs shall be black in colour.

The stockroom lighting shall be 2 way switched where shown.

Supply and install new security lighting, generally where shown on the drawings.

Lighting circuits shall be arranged so that half lighting is provided such as stockroom, general trading area and cashiers area.

All lighting Circuits shall be protected by a RCD.

Warrantees to LED luminaires are currently in place between the lighting suppliers and

Endeavour Group, typically the warranty period of LED luminaires is five (5) years from date of practical completion. The Contractor shall provide warranties to cover the labour for replacement of faulty luminaires for a period of 12 months from practical completion. Liaise with the lighting supplier to organise for replacement parts during this defects liability period.

The guarantee shall cover the cost of material replacement and any reasonable labour charge.

Note: Fluorescent and HID lamp recycling

For refurbishment projects where existing fluorescent tubes or HID lamps are to be removed, a recycling company such as the one below shall be engaged to collect from site and process the discarded lamps. Lamps containing mercury shall not be discarded into the general building waste system.

Eco-Cycle Industries
Phone number: 1300 32 62 92
ecocycle.com.au

4.19.2 LIGHTING INSTALLATION

All fittings shall be installed in an approved manner at the locations on the drawings or in relocated positions as instructed on site.

Suspended ceilings will generally be of the two way fully exposed T-Bar type.

Where fittings are required to be recessed in set plasterboard ceilings they shall be complete with flex, plug, plaster ceiling flanged, mounting brackets and all other items required to be installed in an approved manner.

Where a building structural member does not exist in the position required, the Contractor shall supply and install a unistrut or similar fixing above the lighting fitting for additional support. Noggins provided in timber frame ceilings or walls shall not be less than 75mm x 50mm oregon.

Luminaires shall be securely fixed to structural members of the ceilings or walls, or fixed by hangers or brackets securely fixed to building members.

Ezustrut lighting ladders shall be supported by threaded rods. Use of stainless steel cable hangers are not accepted. Threaded rods shall be directly secured to the lighting ladders by approved methods as per the manufacturer's recommendations.

The minimum size of fixings for luminaires, hangers or brackets for various surfaces shall be as follows:

- Fixing to timber - cadmium plated R.H. wood screws not less than 3.2mm x 25mm long.
- Fixing to concrete - approved screw expanding bolts 6mm diameter x40mm long.
- Fixing to hollow blocks - at deep cast junction boxes with 4.5mm diameter metal screws at the centre of the luminaires, with approved expanding fixing at each end.

All fixings shall be corrosive resistant hot dipped galvanised or equal. Self-tapping screws shall not be accepted.

All light fittings shall be mounted to ensure that electronic control gear are accessible for maintenance.

The Contractor shall allow for all brackets and chain suspension of light fittings as required.

A vandal proof security light shall be installed on the outside of the building over each door as shown on the drawings. When more doors are required to meet the requirements of local authorities then additional lights shall be installed as required.

All luminaires shall be effectively earthed.

Luminaires shall not be used for illumination during construction.

4.19.3 WINE RACK LED LIGHTS

Supply and install LED lights to each shelf within each wine rack as indicated on the plan. Refer to standard Dan Murphy's LED cabinet lighting drawings for further details.

LED Installation

Supply and install the following:

- LED strips to the front underside of each shelf, LED strips to have magnetic backing such that they can be attached directly to the steel frames. Use steel clipping provided with the LED strips to secure to the frames if required. Double insulated LV cabling from the LED strip to the LED power supply.
- Power supply shall be mounted at the top or at the back of the cabinet.
- One power supply unit per cabinet.
- Refer Dan Murphy's LED cabinet lighting drawings for approved lighting suppliers.

Power Installation

Supply and install EMS zoned RCD protected and recessed standard black switched socket outlets as per the standard drawings.

4.19.4 LIGHTING COMMISSIONING WORKS

The Contractor shall adjust all lights to illuminate display fixtures and signage as per the lighting commissioning instructions as provided in the appendices section of this Specification. Lighting adjustment works shall be carried out once all displays and signage are in place which could mean a few days out from store opening. Failure to comply with this requirement shall render the Contractor liable for all costs associated with lighting commissioning works done by others.

4.20 ILLUMINATED SIGNS

Illuminated signs including tower signs, building signs and under awning signs will be supplied and installed by the Sign Contractor at positions as indicated on the drawings.

The electrical detail of each sign shall be obtained by the Contractor who shall carry out all wiring up to terminal connection boxes provided by the Sign Contractor within each sign.

Control of signs shall be by Dan Murphy's Energy Management System (EMS). Supply and install IP66 isolation switches adjacent to each sign.

Provide manual switches for the control of internal illuminated signs. Switches shall be mounted at the Lighting Control Panel.

All external signage signs shall be controlled by a combination of a time schedule and a photoelectric cell via the EMS as indicated in the Electrical Single Line Diagram.

The Contractor shall supply and install tower and fascia sign floodlighting in positions as shown on the drawings.

4.21 CAR PARK LIGHTING

4.21.1 EXTERNAL CARPARK LIGHTING

The external carpark lighting layout shall be designed and installed to meet the requirements of the current lighting standard AS/NZS 1158.3.1:2020. Also, the design and installation shall meet the specific requirements set out within the Local Council By-laws and Planning Permits. The lighting to the general carpark areas such as parking spaces, aisles and circulation roadways shall be designated and designed as **Category PC1**, as defined by AS/NZS 1158.3.1:2020.

The lighting to pram parking spaces and disabled access parking shall be designated and designed as **Category PCD**, as defined by AS/NZS 1158.3.1:2020.

Isolux diagrams showing minimum/average/maximum illuminances and site plans showing lux levels shall be submitted to the Electrical Engineer for approval. The levels shall be indicated for both horizontal and vertical. Design certification shall also be clearly shown on the carpark lighting design ensuring compliance with all codes and standards.

In addition to the above, the lighting design and installation shall meet the requirements set out within the current edition of AS/NZS 4282-2019 (Control of Obtrusive Effects of Outdoor Lighting).

Note:

- No light beam is directed beyond the site boundaries or upwards without falling directly on a surface with the explicit purpose of illuminating that surface and where the design complies with AS/NZS 4282-2019 (Control of the Obtrusive Effects of Outdoor Lighting).
- Particular care shall be taken to minimize direct glare to neighbouring properties. Also, particular care shall be taken in regard to neighbouring residential boundaries for curfew and pre-curfew hours to limit the light spill into neighbouring properties.
- The use of luminaires "back shields" may be necessary to control light spill where luminaires are positioned on boundaries.
- Areas where vacant allotments adjoin the property boundary shall be deemed as future residential areas unless pre-determined otherwise.

Preference shall be given to luminaires that have lighting sources situated well within the lighting fixture to avoid direct glare and, the fixtures should have a system of reflection to minimize unwanted glare, but be controlled for maximum reflection to the designated areas.

Carpark floodlighting shall be of LED technology. Refer to Section 2.2 for approved carpark LED lighting suppliers, other suppliers can be considered by the Endeavour Group Engineer, but may take considerable time to review and approve.

All carpark flood lights and poles shall be supplied and installed by the Contractor and equipment shall be in strict accordance with the manufacturer's recommendations.

Poles in open areas shall be 10m high but lower poles may be permitted in restricted spaces. The poles shall be galvanised steel type complete with outstretched arms as required. Where step irons are not provided, an approved ladder rest shall be incorporated in all poles.

The Contractor is responsible for the excavation and backfilling of conduit trenches for mains, carpark lighting, cabling etc and the installation of holding down assemblies for carpark lighting.

All backfilling to underground pipes shall be sand and crushed rock.

The Contractor is responsible for determining the structural requirement of the poles and

bases and shall guarantee in writing the installation is safe and adequate for all situations. Pole base mountings shall be embedded in concrete to the relevant details. **Appropriate mechanical protection shall be provided to poles that are exposed to vehicular damage.**

The Contractor shall supply and install all underground cable enclosed in pipe from the respective service on the distribution board to the location of the various poles. After installing all poles and flood lights, the Contractor shall make all necessary adjustments to fittings to ensure an even illumination of the carpark area and that annoyance is not caused to adjacent properties.

Control of external carpark lighting shall be by a combination of Photo-electric (PE) cell and a 365-day 24-hour battery backed electronic time switch controlling lighting contactors. The P.E. cell to override the time switch when the natural lighting is lower than the preset level.

4.21.2 INTERNAL CARPARK LIGHTING

Lighting for indoor carparks shall be designed and installed to meet the requirements of AS/NZS 1680.2.1:2008. In addition, the design and installation shall meet the specific requirements set out within the Local Council By-laws and Planning Permits. Special attention shall be given to provide the required illumination levels for car entry areas, ramps, pedestrian crossings and pram and disabled parking spaces as outlined in AS/NZS 1680.2.1:2008.

Carpark lighting shall be of LED technology with minimum 5 years warranty. Proposed LED luminaires shall be submitted to the Endeavour Group Engineer for approval.

Isolux diagrams showing minimum/average/maximum illuminances shall be submitted for approval. Floor plans showing lux levels shall also be submitted for approval.

Control of internal carpark lighting shall be by a 365-day 24-hour battery backed electronic time switch controlling lighting contactors or via the EMS Panel.

4.22 EMERGENCY LIGHTING SYSTEM

The Contractor shall supply and install an emergency evacuation lighting system which complies with AS/NZS 2293. All fittings used shall have been classified by a NATA recognised testing laboratory. All emergency and exit light fittings shall be LED types and have lithium iron phosphate battery cells with minimum discharge of 2 hours initial duration, 90 minutes in-service duration. Approved emergency lighting system is **Clevertronics LP CTP** product range, refer to the Lighting Schedule for details.

The Dan Murphy's emergency evacuation lighting system shall be a separate installation. In the case the store is within a shopping centre, the emergency evacuation lighting system shall NOT be networked to a centralised control and monitoring system. Multi-head emergency lights shall not be used.

All emergency lights and Exit signs shall be connected to dedicated circuits from the nearest lighting distribution board. The circuit breaker shall be fitted with a "lock-dog" and be labelled "Emergency Lighting - Do Not Turn Off". The sensing of power failure shall be connected to the 24 hours security lighting circuits where the designated area is served.

The Contractor shall check the exact mounting position of all emergency lights with other trades before installation to ensure fittings are coordinated with store signage and ceiling services.

Where authorities having jurisdiction require additional facilities, these shall also be provided as part of this contract.

Where fittings shown on standard drawings in the non-trading areas are not required under the standard they shall nonetheless be provided.

4.22.1 GENERAL REQUIREMENTS

Provide a single point exit and emergency lighting system as follows:

Battery:

- Lithium Iron Phosphate cells.
- Battery protection: over voltage in charge, low voltage and over current in discharge.
- Emergency period: 2 hours initial duration, 90 minutes in-service duration.
- Labelling: date of manufacture, ampere hour (Ahr) rating and replacement part number.

Mount battery in location as far as practicable from heat producing components.

NATA Classification:

- Test results of luminaires and components from a registered NATA laboratory shall be made available when requested.
- Classify luminaires in accordance with AS/NZS 2293.
- Be tested in accordance with AS/NZS 2293.3 with respect to Thermal/Duration, and Photometry resulting in a classification.
- Be tested to comply with EMC Standard AS/NZS CISPR 15:2011.

Circuit Breaker Labelling:

- Label all lighting circuit breakers controlling circuits to which emergency lights or exit signs are connected in accordance with AS/NZS 2293.1-2018, Clause 2.5.

4.22.2 EMERGENCY LUMINAIRES

- Self-contained, single point fittings complete with batteries, charger and electronic controls.
- Incorporate long life, low energy LED lamp source.
- Have a minimum design life of seven years.
- The emergency lights shall be suitable to install in building with ceiling height between 3 and 6 metres.
- The minimum AS/NZS 2293.1 luminaire classification for spacing shall be C0/C90 = D32/D25.

4.22.3 ILLUMINATED EXIT SIGNS

- Self-contained, maintained, single point, illuminated exit signs with batteries, charger and electronic controls.
- Incorporate long life, low energy LED lamp source.
- Have a minimum design life of seven years.
- Exit signs shall be both aesthetically and functionally suitable for the intended location and application.
- The Exit signs shall be suitable to be ceiling mounted, wall cantilever, back mounted, rod and chain suspended.

4.22.4 TESTING AND HANDOVER

The Contractor shall provide a certificate from the appropriate authority to state the Exit signs and Emergency lighting conforms to the requirements of AS/NZS 2293 and Authority having jurisdiction over the site.

The Contractor shall supply an Emergency Lighting and Exit Signs Maintenance Log Book. A drawing shall be provided of A3 size to fit across the inside of the front cover and first page, the drawing shall indicate the location of all emergency lights and exit signs. Each light on the drawing shall be numbered so that when making an inspection, the sequence of the numbering allows for a defined path to be taken so that entries in the log

can be made in numerical order. An appropriately labelled Log Book Holder shall also be provided and mounted adjacent to the main switchboard.

Endeavour will engage others to activate the automatic testing feature of the emergency and exit lights, the Contractor shall perform the following works to enable for the commissioning of the system:

- 1) Each installed fitting shall be labelled with the Clevertronics Serial number QR code in a location visible from floor level, 2 QR codes are supplied with each fitting by the manufacturer Clevertronics.
- 2) Each fitting shall be labelled with a unique Fitting ID label in a location visible from floor level.
- 3) Compile the Emergency lighting Baseline Data as per AS/NZS 2293.1
 - Complete a fitting register in accordance with AS/NZS 2293 and ensure the following information is recorded:
 - i. Serial Number (from the QR Code label) of the Clevertronics LP CTP Fitting. This QR code should be adhered to the register next to the correct fitting,
 - ii. Fitting ID,
 - iii. Detailed location,
 - iv. Switchboard and Circuit details
 - v. Product installation date of every installed fitting,
 - The fitting register must be available in a digital format in Excel via USB.
- 4) Provide an as-built emergency lighting layout drawing with fitting locations highlighted and marked with the unique Fitting ID numbers.
- 5) Leave a hard copy of all documentation in the Log Book holder at the switchboard location.

Test the emergency lighting system to the satisfaction of the regulatory authority.

Demonstrate the operation of the emergency lighting system by performing the 12 monthly test as specified in AS/NZS 2293.2 prior to the date of practical completion.

All units which fail to operate for the required period will be rejected and shall be repaired or replaced and shall be similarly tested after repair.

Results of the test at practical completion shall be recorded in the log book.

Rectify all defects, including replacement of failed lamps during the defects liability period.

4.23 BELL SYSTEM

The Contractor shall supply and install the following Bell systems.

4.23.1 STOCK ROOM BELLS

150 mm underdome bells shall be located in the Liquor Storage Area in the positions shown on the plan. The bells shall be 24V operated and shall be activated from a push button adjacent the loading dock. The push button shall be heavy duty weatherproof IP56. The push button shall have screwed traffolyte label "General Deliveries".

4.23.2 STAFF ENTRY BELLS

100mm underdome bells for staff entry in the positions shown on the plan. The bells shall be 24V operated and shall be activated from a heavy-duty weatherproof type IP56 push button. The push button shall be mounted externally adjacent the staff entrance and have screwed traffolyte label "Staff Entry".

4.23.3 ONLINE PICKUP BELL

100mm underdome bell for the online pickup area in the position shown on the plan. The bell shall be 24V operated and shall be activated from a heavy-duty weatherproof type IP56 push button. The push button shall be mounted externally adjacent the online pick up entrance and have screwed traffolyte label "Online Pickup".

4.24 SECURITY ALARM AND CCTV SYSTEMS

4.24.1 GENERAL

The Contractor shall supply and install conduits and wall box complete with draw wire for the provision of Security alarm and CCTV systems. This shall include the supply and installation of dedicated UPS socket outlets with flat earth pins. Dan Murphy's will arrange for supply and installation of the Security Alarm and CCTV Systems.

The conduits shall go inside a wall or door jambs to above false ceiling only. Conduits shall be installed as shown on the standard drawings and as specified herein. All conduits shall be blown clear of debris and left complete with a galvanised steel draw wire.

It is the Contractor's responsibility to co-ordinate with the security and CCTV Contractor regarding the final location.

4.24.2 EXTERNAL DOORS

Supply and install a 20mm conduit from an accessible position in the roof space to a location in the head of all external doors. The conduit shall terminate 150mm from the lock side of single leaf doors above the door inline with the conduit.

Above double doors the same shall apply but with an additional hole above the second door 300mm away from the first hole.

4.24.3 STORE LIGHTING INTEGRATION

The store's lighting control system is to be linked to the security alarm panel such that in an event of a break-in, the security panel will activate to bring all internal lights 'on'. Store lighting will remain on for no longer than ten minutes before automatically resetting. To facilitate this function, the Contractor shall provide a 2-core 1.5mm² signal cable between the EMS panel and the alarm panel, and terminate the signal cable at the EMS panel. Termination of the signal cable at the alarm panel is the responsibility of the security installation contractor.

4.25 PUBLIC ADDRESS SYSTEM (PA)

The following shall be supplied and installed by the Contractor for the PA System. All conduits shall be blown clear and equipped with a galvanised steel draw wire. The Contractor shall co-ordinate with the PA Contractor regarding the final location.

- Steel cable basket or duct from the PA amplifier location to the ceiling space.
- A minimum 100mm x 100mm sheet metal duct or a dedicated section of a cable tray from the PA amplifier location to the cashier area shall be provided in the ceiling for use by the PA Contractors. This duct shall be labelled 'PA System' and shall be used for installing cables to the cashier area, trading area and other back of house areas. Where cable tray is used, the PA section shall be mechanically separated with a metal divider or has a minimum of 300mm gap from power services.
- 20mm conduit from the roof space to each wall mounted speaker and volume control location. Where finished wall surfaces are provided, this conduit shall terminate in a standard wall box set in the wall. For hollow block wall, provide surface mounted mounting blocks.
- 20mm conduit from each microphone point in all offices and workstations to the roof space. Where finished wall surfaces are provided, this conduit shall terminate in a standard wall box set in the wall. For hollow block wall, provide surface

mounted mounting blocks.

- Where the PA front-end equipment is not located in the SCS BD cabinet, allow a dedicated UPS circuit and a double socket outlet with flat earth pin at a location to be nominated by the PA contractor.
- Provide access to metal ducting to enable the PA contractor install audio cabling such as in the office area.

4.26 MECHANICAL AND REFRIGERATION SYSTEMS

These systems will be provided by others, but included in this Specification is the supply, installation and termination (both ends) of the individual submains to the mechanical, refrigeration, essential services, and smoke exhaust switchboards.

The Contractor shall include all accessories, cable glands and hardware necessary. The switchboards will be located as shown on the relevant drawings.

4.27 MECHANICAL FIRE TRIP (WORK BY OTHERS)

The Fire Services Contractor shall supply and install all equipment (not otherwise supplied) necessary for the tripping of the Mechanical Services systems in the event of the fire sprinkler system operations or when the smoke or thermal detectors sense a fire.

This shall consist of an ELV system (24V, 50Hz) in which a circuit via normally open (N/O) contacts of a pressure switch (supplied by others) in the sprinkler system or from a fire indicating board energised relays (supplied by others) in the Mechanical Services systems control panels.

The transformer to supply the system shall comply with AS C126 and be installed in a Distribution Board or other suitable metal enclosure. It shall be rated at 200 VA and shall have the secondary side fused. If installed in a distribution board, the board shall be labelled to indicate the location of the transformer and the fuses shall be accessible without the necessity to remove the panels.

All wiring between the pressure switch, relays and power supply shall be run in PVC cables, sheathed or enclosed in conduit, and of adequate size so that the voltage drop does not exceed 5%.

4.28 FIRE SERVICE

Fire rated cables shall be installed in accordance with the manufacturer's recommendations and requirements. Fire rated cables shall be M.I.M.S., Fireguard or Radox. All fire rated cables shall use copper conductors.

Cable subject to mechanical damage shall be mechanically protected. All fire rated cables shall be fixed to cable tray by metal saddles maximum 600 mm centres.

Where M.I.M.S. cable passes through ferrous metal adequate protection against eddy current shall be provided. Purpose made gland plates shall be used. M.I.M.S. cables shall be straightened before installation, run on parallel paths with properly radius curves and secured by copper saddles. Single core cables shall be used. Metal-sheathing shall not be used as earth cable.

4.28.1 MAIN CONTROL

The Contractor shall provide a separate Essential Services switchboard located in the main switch room. Provide a Fire Service Control Circuit Breaker of adequate rating, connected directly to the main busbars for the installation of an approved fire rated submains to a fire control panel as required by the State Statutory Authorities.

4.28.2 SUB-MAINS AND SUBCIRCUITS

Where such fire services are required the Contractor shall supply and install copper fire rated submains from the Generator DB circuit breaker to a fire control panel, Fire indicating Panel (FIP) and Sprinkler jacking pump, hydrant booster pump(s) provided by the Fire Service Contractor.

Provide lighting and hose-proof socket outlets as required within the firepump room, Sprinkler Control Valve room, all wired with fire rated cables.

The circuit breakers for the fire services shall be labelled 'Fire Pump – IN THE EVENT OF FIRE DO NOT SWITCH OFF'.

4.28.3 FIRE CONTROL PANEL

The fire control panel shall comply with the requirements of the AS/NZS 3000 Wiring Rules with respect to emergency services.

4.28.4 FIRE ALARM CONNECTION

Where fire service provisions are made, the Contractor shall supply and install a 2-core copper fire rated cable from the building telephone main frame distributor to the sprinkler alarm telephone relay or switchboard provided by the Fire Services Contractor. Alternatively, the Contractor shall comply with the requirements of the local fire authority.

If no alarm system is available to the local Fire Brigade the Contractor shall arrange for the alarm to be connected to the store security system.

The Contractor shall wire from the sprinkler valve room to the security system control unit using twin PVC sheathed continued cable. The Fire Services Contractor will supply and install a pressure switch that will open circuit on the operation or testing of the sprinkler system.

The Contractor shall arrange for the connection at the security alarm panel and shall make all other necessary connections and arrange with the Fire Services Contractor, the local Fire Brigade and or Security Contractor for testing and commissioning.

4.28.5 INTERIOR FIRE ALARM

A 24V bell and light shall be supplied and installed in a position shown on plan adjacent the administration offices.

The bell and light shall signal the operation or testing of the Fire Sprinkler or Fire alarm systems.

Supply for this alarm shall be from the transformer serving the Air Conditioning fire trip and shall operate on the opening of the pressure switch contacts of the sprinkler or the fire indicating board via a relay with normally- close (N/C) contacts.

Wiring shall be carried out using twin PVC cable sized to ensure that the voltage drop measured at the terminals of the bell and light does not exceed 5% when both are operating.

The bell, light and relay shall be housed in a suitable fire resistant enclosure. The light shall be mounted behind a blue lens and bezel, the bell shall be mounted behind a suitable grill. A test button shall be provided to open circuit the relay to test both lamp and bell.

4.28.6 OPERATION OF MALL ROLLER SHUTTER DOORS IN FIRE TRIP MODE

Mall roller doors shall be partially lowered (to prevent smoke spill into mall) in fire trip mode if required by the Fire Engineering Design. The final position of doors (distance from ceiling) in fire trip mode shall be determined by the Fire Engineering Design. The lowering

of the doors to the required height (Third Limit) shall be achieved by a fire signal to a Grifco Special Mini Expansion Board P / N MINEB - C1 (or approved equivalent) install to each roller door motor. Power to roller door shall be provided from the Dan Murphy's Essential Service switchboard located in the plantroom. All power and control wiring shall be fire rated (MIMS or Radox only).

4.29 FINISHES

All exposed steel conduits, metalwork, angle iron brackets, suspension rods, woodwork etc. unless otherwise directed, shall be treated with two coats of best quality paint in approved colours, one coat being applied before erection.

The paint finish on all fittings and equipment supplied and/or installed, shall be in a perfect condition. Blemishes shall be repaired and, if necessary, the equipment repainted to the satisfaction of Endeavour Group.

4.30 STANDBY GENERATING SET

The Contractor shall supply and install an approved generating set which shall comprise of a diesel engine driven alternator complete with controls and instrument cubicle, fuel tank, exhaust silencer and interconnecting cables.

The generating set shall be of automatic start on power failure and shall be installed as shown on the drawings.

The generator set shall be a 22kVA 240V single phase 50 Hertz alternator coupled to a diesel engine.

The generator shall be designed and installed to meet the latest AS/NZS 3010:2017 'Electrical installations – Generating sets', in particular allow for a lockable isolating device for maintenance purposes and that the neutral conductor shall not be switched with a permanent single phase generator (i.e. the neutral connection shall not disconnect the connection to the main switchboard MEN link connection).

The manufacturer will also supply fuel level gauge, fuel hoses and clamps, muffler, on-line test facility, battery charger and battery, control cubicle and interconnect cables between cubicle and generator, drip tray, installation instructions and other incidental items.

The Contractor shall supply and install an exhaust pipe from the diesel engine up to two metres above roof level. It shall be located such that there is no possibility of fumes entering the air conditioning intakes or enclosed areas. The Contractor is to co-ordinate with the builder to provide support to the exhaust pipe if required.

The exhaust shall comprise of galvanised steel 50mm N.D. pipe and have a rain cap to prevent the ingress of water to the engine. The Contractor shall arrange for flashing around the pipe where it passes through the roof to be done by the Builder. There shall be no leakage of exhaust fumes whatsoever from the engine to the end of the pipe.

The generator set shall be securely fixed to the floor by the Contractor who shall make the connections between the generator and control cubicle with the cable provided and also supply and install a 1 phase sub-main from the MSB to the control cubicle.

The generator set shall provide standby power in the event of mains failure to the Generator DB.

The Contractor shall fill the fuel tank with the recommended grade of fuel after all tests and commissioning. A 20 litre 'jerry can' shall be supplied and suitable funnel for topping up fuel tank, the jerry can shall have a permanent label or inscription with text '**DIESEL ONLY**' to ensure refill of the correct fuel. Provide a holding bracket for the 'jerry can' and funnel.

A three pole 160 amp A.C.3 55° rating contactor shall be provided in the control cubicle that

shall close on generator start up and provide supply to essential switchboard.

The engine shall be a naturally aspirated diesel, 4 cylinder 1500 RPM type, 12V battery start with engine safety shutdown for low oil pressure, high engine temperature and engine over speed. The engine shall have a heavy duty tropical radiator with guard protection and industrial grade silencer.

The brushless alternator shall be flange mounted, self-exciting with electronic automatic voltage regulation.

The generator shall have a heavy duty powder coated steel base incorporating anti- flex plates and a 170 litres diesel fuel tank with a contents gauge. Provide anti- vibration mounts between the generator and plant room floor.

The control cubicle shall include volt, frequency, current and hours run meters. Provide a 240V constant automatic battery charger. Provide a main power failure controller and phase failure relay in the control cubicle. Change-over contactors rated at 30kW AC3, mechanically and electrically interlocked, arranged to switch active and neutral simultaneously.

The changeover contactor set shall have 2 pole contactors (active and neutral) for both normal supply and generator supply, the mains neutral need not be switched. The contactors shall be mechanically latched and electrically operated.

If not installed in the Plantroom, supply and install a genset barrier. The barrier shall be to approval to provide protection from pallets and associated goods and other items so that the genset remains clear for operation and maintenance at all times. The railing dimensions shall be a minimum of 3000mm x 1500mm.

The barrier shall be securely fixed to the floor and surrounding walls. Provide a 150mm sized angle iron bolted to the floor to impede the forks of pallet jacks entering the space in the zone from the floor to 150mm above the floor. In addition a pipe rail should be provided to protect a pallet from entering the space, located mid upstandard pallet. The protection shall be provided on all sides of the genset that is not a fixed wall.

The railing shall be cylindrical 65mm dia. piping with clamps for securing horizontal and vertical members together. The railing and angle iron shall be painted yellow. De-grease the railing and angle iron, prior to painting. Provide one coat of industrial type primer and two powder coats of industrial type yellow paint.

Where required, supply and install the generator in an acoustic and weatherproof enclosure if located outside the building.

Carry out manufacturer's recommended tests and full load test to prove generator integrity. The whole system shall be tested and commissioned by the Contractor. Advise the Endeavour Group Engineer to witness test the system and give final approval of the systems operation. On completion, after tests and commissioning, fully fill the fuel tank with the appropriate grade fuel.

Provide a Log Book and Labelled Log Book holder mechanically fixed adjacent to Generator.

An engraved label of white text on a red background with 8mm high text shall be mounted in a prominent position at the Generator Distribution Board:

<p style="text-align: center;">WARNING</p> <p style="text-align: center;">THE GENERATOR DISTRIBUTION BOARD MAY HAVE ITS POWER SUPPLIED FROM THE MAIN SWITCHBOARD OR THE GENERATOR CONTROL PANEL UNDER MAINS FAILURE CONDITIONS</p>

Provide a professional written sign near the genset on the adjacent wall (25mm red on white lettering) as follows:

IMPORTANT NOTICE

THIS GENERATOR WILL START UP WITHOUT WARNING. UNDER NO CIRCUMSTANCES SHALL LOOSE ITEMS BE PLACED ON TOP OF THE GENERATOR OR WITHIN THE BARRIER.

4.31 ENERGY MANAGEMENT SYSTEM (EMS)

The Contractor shall supply and install relays, contactors and associated control wiring for the control of the store lighting. The Emerson EMS Controller Unit shall be provided by others, however the Contractor shall provide control wiring to the EMS Controller Unit including termination of cabling to the designated input points. The Contractor is to assist the BMS (EMS) Contractor with the commissioning and testing of the lighting control system.

4.31.1 LIGHTING ZONES

Lighting throughout each store is divided into several lighting zones to enable segregation and to facilitate switching of the lights for Trading Hours and After Hours activities such as Cleaning and Stock Replenishment/Night Fill. The Zones, digital control, relays and cable identifiers are defined in the table below.

Zone	Illuminated Area	Relay	Cable identifier
1	50% Trading Area	R1	Z1
2	Remaining 50% Trading Area	R2	Z2
3	Entrance/Cashier Lights	R3	Z3
4	Refrig & Non-refrig Cabinet Lights & Internal Signage	R4	Z4
5	Entry Awning & External Lights	R5	Z5
6	External Signage & Pickup Awning	R6	Z6
7	Back of House Lights (including offices, staff amenities, liquor store/stock room, loading dock)	R7	Z7
8	Dining Room Hot/Cold Water Unit	R8	Z8

4.31.2 LIGHTING CONTROL STRATEGY

Each lighting zone is switched via a digital output (DO) in the EMS Panel. This DO is wired to the appropriate lighting Distribution Board, where an interposing relay is switched. This interposing relay in turn will switch the appropriate contactor(s), dependent upon the number of lighting circuits in the zone. The contactors are Normally Closed allowing a failsafe condition on which the lighting is switched 'ON' should the contactor coil or the control circuit fail.

Zone 1 and Zone 2 are split 50/50 with the circuits shared across the whole of a particular area. Zone 1 and Zone 2 are alternated on a day to day basis.

4.31.3 SYSTEM LAYOUT

The general wiring of the EMS application at a typical Dan Murphy's Kit is shown on the EMS Schematic. The EMS provides lighting control with 24VAC digital outputs in the Emerson EMS Panel. The digital outputs are connected to remote relays associated with contactors in series with lighting circuits in the distribution boards. Each relay will fire one

or more contactor as grouped in the distribution boards. Contactor poles are normally closed which allows manual control at the distribution boards in the event of EMS failure.

4.31.4 LIGHTING CONTACTOR/RELAY PANEL

Supply and install contactor/relay panel in the switchboards. The EMS Controller should provide control signal to the 20A Contactors/relays to switch ON and OFF the store lighting. The contactors/relays should be housed in the distribution boards with labelling "Lighting Control Contactor/Relay".

Relays & Contactors

The relays and contactors are to be mounted inside the relevant DB.

Most lighting zones are controlled by relays/contactors inside the distribution boards. Multicore from the EMS Panel to DB shall be used to send the 24VAC control signal to the relays.

Materials

The Contractor shall provide all materials to complete the electrical installation except for the EMS Panel. Particular material specifications are:

- Normally open Single Pole Relays

Manufacturer	Weidmuller
Part No.	ECO30
Coil Voltage	24VAC/DC
Switching Output	10A @ 250VAC / 10A @ 20VDC
- Single pole double Throw Relays (Power Monitoring Relays)

Manufacturer	Omron
Part No.	G2R
Coil Voltage	240VAC
Switching Output	Dry Contact (NC)
- 4-Pole N/C Contactors:

Manufacturer	Part No.	Rating
Schneider	GC2504M5 A9C20837	25A
Alternative suppliers providing same performance is acceptable subject to Endeavour Group Engineer's approval.		

- 2-Pole N/C Contactors:

Manufacturer	Part No.	Rating
Schneider	GC2502M5 A9C20736	25A
Alternative suppliers providing same performance is acceptable subject to Endeavour Group Engineer's approval.		

- Multicore, 7/0.30 (20AWG) screened cable, e.g. Olex Instrolex order code IEC183AA020.

EMS Panel Terminations

The EMS Panel shall have 240VAC supplied from the UPS Distribution Section. A Circuit breaker shall be installed to provide an isolation circuit for the EMS Panel. This will feed

the 24VAC transformer and shall include suitable earthing connections.

Refer to standard drawings for additional details on wiring requirements for the EMS.

4.31.5 MONITORED INPUT POINTS

The following input points are monitored by the EMS system and suitable alarms raised when the input point is activated. All input points are to be Normally Open and Voltage Free. That is they will go short circuit to indicate a change of state. The circuit breaker that supplies 240VAC to the relays shall have a power monitoring Normally-Closed relay across the circuit breaker to monitor current through the circuit breaker. When the circuit breaker is open (switched Off), a dry-contact on the relay should close to signal the BMS digital input.

Input	Digital Input	Cable Identifier
Security System Alarm Input	IP1-1	IP1-1
Trading Lights Override	IP1-2	IP1-2
Light Level Sensor Input	IP1-3	IP1-3
Lights Control Power On	IP1-4	IP1-4

4.31.6 SECURITY SYSTEM ALARM INPUT

The Electrical Contractor is to supply and install cabling between the EMS Panel and the Security Alarm Panel for the alarm monitored input. The Security Contractor to terminate the cable within their security panel.

4.31.7 LIGHTING OVERRIDE SWITCH PANEL

A lighting override switch panel shall be installed in the general office. Allow for a multi-core cable linking the override switch panel and the EMS Panel. The override switch panel shall be supplied by the Refrigeration Contractor.

4.31.8 DAYLIGHT LINKING CONTROL

External lights and illuminated signs shall be controlled by a combination of EMS and a light level sensor. The Electrical Contractor is to install the light level sensor and wire the sensor to the EMS panel. The light level sensor shall be supplied and programmed by the Refrigeration Contractor as follow:

- External illuminated signs: Lights to automatically switch 'on' when the external lighting level is below 500 lux, and 'off' at store's closing time by EMS.
- All external lights: Lights to automatically switched 'on' when the external lighting level is below 500 lux, and 'off' when lighting level is above 700 lux (i.e. lights on from dusk to dawn).

4.31.9 TESTING & COMMISSIONING

The Electrical Contractor shall liaise with the Project Manager and Store Manager to obtain a lighting operating schedule such that the information is at hand at time of lighting control commissioning by the BMS contractor. Use the 'Lighting Operating Hours Request Form' in the appendices to assist with the programming of the lighting time schedule.

Assist the BMS contractor with testing and commissioning of the lighting control system.

4.32 STRUCTURED CABLING SYSTEM

Supply, install and test a new SCS data installation as detailed in the latest version of the Woolworths Stores SCS Specification and as detailed in the standard SCS data layout drawings. The works shall only be carried out by an approved Woolworths IT Data Cabling

Contractor.

4.33 UNINTERRUPTIBLE POWER SUPPLY (UPS)

Woolworths IT shall arrange and pay for the supply, install, test and commission the 10 kVA Uninterruptible Power Supply (UPS) system for power supply to computer systems and equipment.

The Contractor shall supply, install and connect submains cables to the UPS from DB-Gen and to DB-UPS.

The UPS Contractor shall supply and install a UPS bypass switch directly behind the UPS unit including termination of cables.

4.34 MASTER ANTENNA TELEVISION (MATV) SYSTEM

The Contractor shall supply and install all cabling, wiring and equipment associated with MATV system. Installations shall be capable of receiving all local free-to-air TV channels and shall be mounted on the roof, as near as practical, above the internal installation or as directed by the Builder and/or Endeavour Project Manager.

If necessary, the mast(s) shall be guyed and the guys shall be carried on the main building support members, flashed where necessary. All guy fittings shall be hot-dipped galvanised or plated finish.

The television system shall receive and distribute all inputs as connected via the input equipment.

The location of all antennae outlets are indicated on the drawings.

The Contractor shall guarantee a clear picture and sound reception on all channels. The system shall be capable of receiving coloured television transmissions and shall conform to AS/NZS 1367.

The system shall include:

- a) Central TV Receiving Antennae
- b) Mast Head and/or distribution amplifier(s)
- c) 75 ohm co-axial cable
- d) Passive components, splitters, spurs, tee units, equalisers etc
- e) 75 ohm outlet plates
- f) Power to amplifier(s).

The MATV system shall cater for at least 5 TV outlets.

Under no circumstances shall any transmission line remain unterminated. All components of the system which may require maintenance shall be accessible to authorised personnel for checking, adjustment or repair.

Connection to the centre's MATV for free-to-air TV channels is acceptable subject to approval from the landlord. Provide all necessary equipment to ensure clear picture and sound reception is achieved for all antennae outlets as indicated on the drawings.

Cabling: All distribution cables shall be coaxial – RG6Q (Quad shield) as a minimum. No cable joins are permitted in the installation, other than at the connections to the systems components. Cables shall be screened to the levels recommended in AS/NZS 1367.

Amplifiers: Amplifiers shall be fully solid state.

Output Plates: Outlet plates shall incorporate twin 75 ohm coaxial sockets. Attenuation between the outlets shall be not less than 32db to minimise the effects of receiver to receiver

interference. Face plate and mounting details shall be identical to adjacent GPO's.

Fly Leads: Supply and install a 75 ohm coaxial fly lead 1500mm long with moulded PAL male connectors at each end for each AV outlet.

4.35 MOBILE NETWORK 'YAGI' ANTENNA CABLING

In the event the fixed line telecommunication services (NBN or copper line) are inoperative, backup telecommunication services to the Store will be provided by the mobile network via use of a 4G modem which is located at the SCS BD cabinet. The modem will require connection to a directional or 'Yagi' antenna placed on the rooftop.

The Contractor shall supply and install the antenna cabling from the SCS BD cabinet to the same location as the MATV antenna (using the same cable pathway). Allow 3m of surplus cable on top of the BD cabinet and 5m surplus at the roof platform where the MATV antenna is located.

Yagi antenna cable shall be type ECE-RG8 50 Ohm Coaxial cable. Contact the following Telstra representatives to source this specified cable:

Ajay.Khanna.2@team.telstra.com or Michelle.Karras@team.telstra.com .

Supply, installation, testing and commissioning of the Yagi antenna and modem shall be done by others.

4.36 NBN SERVICES RELOCATION

Where an existing site has NBN infrastructure and the development or refurbishment requires relocation of these services, the Contractor shall be responsible for the relocation of NBN equipment including paying of all fees and charges with the relevant authorities. Generally, NBN services are to be relocated to the comms room where the BD data cabinet is located, or at an alternative location as nominated by the Woolworths IT Stores Delivery Coordinator (SDC) or Project Manager. The upgrade work may include installation of new NBN equipment subject to assessment by NBN Co, allow for this work to enable a fully functional telecommunication system for the store.

The Contractor is to manage the relocation works with NBN Co. using the following procedure as a guide:

- 1) Raise request with NBN Co to have the works completed using the form via the below link. Note that the Contractor or its principal contractor is to submit the form as soon as possible once NBN equipment is determined to be relocated as there may be a significant lead time (potentially 8-12 weeks) required for NBN Co or its subcontractors to conduct the work.
- 2) <https://www.nbnco.com.au/develop-or-plan-with-the-nbn/commercial-works>
- 3) NBN Co will make contact with the Contractor and provide a quote to carry out the works. NBN may require a site visit to identify the scope.
- 4) The Contractor is to pay the initial fee by NBN Co before work can commence.
- 5) Work will then be scheduled between the Contractor and NBN Co. The Contractor is to notify the Endeavour Group Project Manager and IT SDC the scheduled date and time as the site will rely on the 3G/4G backup whilst the relocation takes place. Any telecommunications outage works shall be conducted outside trading hours and at a time agreed with the Project Manager. SDC will review 3G/4G signal strength and arrange for installation of a Yagi antenna prior to the work being completed if required.
- 6) NBN equipment to be installed in the Elec/Comms Room next to BD cabinet, with the required power and data installed by the Contractor.

Any questions with regard to the above work can be directed to:
engineering@woolworths.com.au

5. TESTING APPROVALS & MAINTENANCE MANUALS

5.1 GENERAL REQUIREMENTS

The Contractor shall carry out all tests required by Endeavour Group to prove that all the electrical works comply with the requirements of this specification.

Endeavour Group require that each item of electrical plant, RCD and equipment shall be tested prior to being energised as per AS/NZS 3760 and AS/NZS 3000. Test and tag all leads as necessary and record all test results in an approved on site hard copy "record log book". The record book shall be included in the Operational and Maintenance Manual.

Tests required prior to energising:

- Insulation resistance measurements on cables and wiring to AS/NZS 3000 and AS/NZS 3017.
- Earth resistance measurements to AS/NZS 3000 and AS/NZS 3017.
- Confirmation of effective earthing of the exposed metal of electrical equipment.
- Full functional and operational checks on energised control equipment and circuits, including adjustments for the correct operation of safety device.
- Test on RCD's using RCD tester plug into the Socket Outlets and 3-phase test unit for 3-phase equipment. The trip unit shall operate the RCD's at 30mA.
- Balancing of load at each distribution board.
- Polarity measurements
- Fault loop measurements

During testing, replace fuses and equipment damaged or faulty as result of incorrect installation works.

The Contractor shall provide all calibrated test equipment and labour for carrying out the tests.

The Contractor shall arrange for the installation to be inspected and passed by the Supply Authority. Provide a written certificate to the effect that the installation has been tested and passed by the Supply Authority or other certified testing Authority.

All of the above tests shall be carried out prior to the end of the Dan Murphy's fit out. The Contractor shall make arrangements with Endeavour Group to have the test results as submitted by the Contractor verified by independent tests carried out by the Endeavour Engineer. The Contractor shall be in attendance at these tests and shall provide all necessary assistance to enable the tests to be carried out. At least seven days notice shall be given to when the tests may be carried out before the end of the fit out period. This will normally be within three weeks of handover of the store by the Builder to Endeavour Group.

5.2 TESTS AND APPROVALS

It is the intent to ensure that all workmanship, all material employed, all required equipment and the manner and method of all installation conform to the accepted construction and engineering practices and that each piece of equipment is in satisfactory condition to successfully perform its functional operation including its maintenance.

Any equipment which is installed in a position where it is difficult to maintain will be rejected. All necessary meters, instruments, temporary wiring and labour to perform all required tests and adjustment of equipment and wiring installed and connected shall be supplied.

Tests shall be made for continuity and identification of each conductor. Both ends of a given conductor shall be identified alike. Before circuit terminal connections are made, continuity and identification shall be checked by means of a DC test device using a bell or

buzzer, or battery powered phone to runout the wires.

Each circuit shall be tested for grounds and shorts by means of a 'megger' insulation testing instrument. In order to avoid damage to electrical apparatus, the Contractor shall conform to the following testing procedures.

For all power circuits, the testing voltage shall be 500V DC. The contractor shall disconnect all apparatus plug-in the socket outlets, turn the isolating switches of all permanent connected electrical equipment to OFF position and disconnect the cables from the RCD's on the switchboard before meggering. For all lighting circuits, the testing voltages shall be 250V DC. Any circuits showing an insulation resistance less than the minimum values given in the AS/NZS3000 Wiring Rules shall be investigated and defects corrected. All circuits under 'megger' insulation test shall be connected to respective final terminals with switches in the OFF position. Reinststate and reconnect all apparatus and cables after the tests.

Test all earth connections for continuity using a similar instrument.

Correct or replace any normal current carrying circuit which is defective or earthed. Also correct all faults encountered by test and set breakers as directed, so that equipment will be in proper operating condition before being placed in service.

Following established procedure, equipment will be energised after certification that the installation is satisfactory. Final operation tests shall determine that the wiring connections are correct.

Carry out polarity and phase sequence tests for all power circuits.

6. OPERATION AND MAINTENANCE MANUALS

6.1 INSTRUCTION MANUALS, CIRCUIT DIAGRAMS & DRAWINGS

Upon completion of the contract, the Contractor shall provide one (1) set in hard copy and two (2) sets in USB flash drives of the Operations and Maintenance (O&M) Manual including 'as installed' drawings for the Electrical and SCS Cabling installation of the store. USB flash drives shall have files in Word, Excel, PDF and AutoCAD formats as applicable.

As-built drawings shall include, but not be limited to, the following:

- Switchboard layout drawings showing the arrangement of equipment within the switchboard, busbar arrangements and methods of achieving segregation, dust-proofing, etc, complete with all necessary dimensions.
- Detailed layout drawings for Lighting, Power, SCS Data and Scale showing the arrangement of equipment, provisions for terminating all incoming cables, etc, complete with all necessary dimensions. The layouts shall show all cable tray, cable pathways and specific application devices with attendant outlet locations marked accordingly. The drawings shall include single line diagrams, all conduit and cable duct runs. Provide accurate dimensions for all underground cable runs, pipes and pits.
- Wiring and schematic diagrams of the equipment incorporating all circuitry shown on the drawings.
- For the SCS Installation document, the requirements are detailed in the SCS specification.

The drawings shall be submitted along with the operations and maintenance manuals.

6.2 RECORDS AND DOCUMENTATION

- Contractors test results – Hard copy and Soft copy.
- Signed off copies of completed acceptance test schedules.
- Warranty and Certificates.
- Circuit breaker cascading and discrimination reports.
- Equipment and installation operational and maintenance instructions.
- Supply a RCD test and Emergency Lighting log book in the Elec/Comms room together with labelled wall mounted holders for each.

The front of the binder shall be machine embossed with:

ENDEAVOUR GROUP
 "NAME OF STORE"
 OPERATION AND MAINTENANCE INSTRUCTION FOR
 ELECTRICAL INSTALLATION

The documentation contained shall include all data relevant to all equipment AS FINALLY INSTALLED including at least the following:

- Service Contacts - Listed name, address, telephone number and facsimile number for the installer, manufacturer and agent for each and every item of equipment.
- Certification - Manufacturer's guarantee, installer's certificate of completion, Notification of Completion of Electrical Works to Electricity Authority, SCSs certificate form TCA1 and catalogue sheets for each item of equipment, including tester calibration certificates and spare parts list.
- Test Reports - Copies of all signed off test and data sheets for all continued factory and field proving tests carried out on the plant and equipment; copy of certificates for the test and tag of all electrical appliances and equipment, Electrical Installation works complies ACA standards, SCS test result certification from VTI Services (Tel 02 9824 2412).
- As-installed Drawings - A copy of all up-to-dated workshop drawings prepared and approved including schematics and as installed layout drawings.

- Signed Electrical Compliance Certificate as provided in the appendices section.

The drawings shall show the as-installed locations of all equipment, full circuit diagrams, the location of all cable runs, and the as-installed arrangement of the equipment, cabinets, panels and all relevant information which would assist in the carrying out of maintenance additions and/or alterations to the installation.

Operations and Maintenance manuals which indicate the type and frequency of maintenance work to be carried out shall be prepared. It shall include details of the various items of equipment used, the name, address and telephone number of the installer, the local service agent for spare parts and copies of the installation and maintenance information and test results for the electrical installation. One copy of this manual will be handed to the Woolworths representative at the time of handover.

Distribution of the manuals is to be as follows:

- The hard copy and 2 x USB flash drive of the O&M Manual to be submitted to the Endeavour Group Project Manager - the hard copy and one USB flash drive be kept on site within the General Office.
- As-built drawings both in PDF and AutoCAD formats shall be sent to the follow email address engineering@woolworths.com.au

Final payment may be withheld until all drawings and manuals are received.

6.2 SCS CABLING SYSTEM RECORDS AND DOCUMENTATION FOLDER

Refer to Structured Cabling Specification.

6.0 DAN MURPHY'S STANDARD DRAWINGS

The following list of Dan Murphy's Standard drawings shall be used as the basis and reference in the design and documentation of the Electrical installation for a Dan Murphy's Liquor Store. The Standard drawings shall not be used as construction drawings.

Use the information and details provided in the standard drawings to produce fully detailed drawings for the project.

To enable drawings to be approved by Dan Murphy's without delay, use the symbols as per the Dan Murphy's standard drawings.

Drawing No.	Description
DME600	Cover sheet & drawing index
DME601	Lighting concept layout
DME602	Power layout
DME603	Cable way layout
DME604	Electrical single line diagram
DME605	SCS data layout
DME606	Public address layout
DME607	CCTV & Security layout
DME608	LED cabinet lights

APPENDIX A – CONTRACTORS COMPLIANCE CERTIFICATE

PROJECT:
LOCATION:
CONTRACTOR:

We certify that the above installation has been completed in accordance with the following requirements:

1. Dan Murphy’s Ltd Standard Electrical Specification and Drawings and the site specific requirements of the Project.
2. The installation complies with all applicable Codes, Australian Standards and Authorities having jurisdiction over the installation and that the installation has been passed by the appropriate Supply Authority.
3. RCDs as installed, complies in all respects with the latest edition of AS/NZS 3000 Wiring Rules, State Building Regulations and Dan Murphy’s Standard Specification.
4. The Emergency Evacuation Lighting System as installed, complies in all respects with the National Construction Code, State Building Regulations and Australian Standard AS/NZS 2293. The Emergency Evacuation System Log Book has been completed and initial test results entered. The Systems will be maintained in accordance with AS/NZS 2293 for a period of 12 months.
5. The suspension hanger systems were installed as follows (cross out where not relevant):

Gripple No. 1 for Track Lighting:

At 1800mm maximum spacing – maximum of 10kg between two hangers (5.6kg/m)

Gripple No. 2 for Linear Trunking/Extrusion Lighting:

At 1800mm spacing – maximum of 45kg between two hangers (18.8kg/m)

At 2400mm spacing – maximum of 45kg between two hangers (25.0kg/m)

Installation was done as per the manufacturer’s recommendations and guidelines as outlined in the ‘Woolworths Lighting Suspension Installation Guide’.

6. The Communications In-Store Cabling and SCS installation has been installed and tested, and the test results together with the Drawings of the Cabling Installation have been entered in the Manual.

The installation will be maintained for a period of 12 months from the date of Practical Completion.

(A signed copy of this certificate shall be included to the operations and maintenance manuals, both in hard copy and electronic copy on USB flash drives).

Signed: Date

Name:

Position:

Company:

APPENDIX B – LIGHTING OPERATING HOURS REQUEST FORM

STORE NAME:

STORE NUMBER:

STORE MANAGERS NAME:

STORE TRADING HOURS	MON	TUE	WED	THU	FRI	SAT	SUN
OPEN							
CLOSE							

Explanation of Terms:

'PRE 50%' – 50% of lighting will switch ON before store opening time.
 'PRE 100%' – 100% of lighting will switch ON before store opening time.
 'POST 50%' – 50% of lighting will switch OFF after store closing time.
 'POST 100%' – 100% of lighting will switch OFF after store closing time.

Example: If store opens at 7am and closes at 10pm:
 a) If 'PRE 50%' is set at 60mins □ 50% of lighting will turn ON 60mins before trade (6.00am).
 b) If 'PRE 100%' is set at 15mins □ 100% of lighting will turn ON 15mins before trade (6.45am).
 c) If 'POST 100%' is set at 15mins □ 100% of lighting will turn OFF 15mins after trade (10.15pm).
 d) If 'POST 50%' is set at 120mins □ 50% of lighting will turn OFF 120mins after trade (12 midnight).
 Note: Even though 100% lights are turned OFF after 15mins as in (c) above, 50% of lighting will still remain ON as it is set to operate for another 120mins after trade closes.

Note: Duration to be in minutes.

ALL TRADING AREAS

	PRE 50%	PRE 100%	POST 100%	POST 50%
MON	___ mins	___ mins	___ mins	___ mins
TUE	___ mins	___ mins	___ mins	___ mins
WED	___ mins	___ mins	___ mins	___ mins
THU	___ mins	___ mins	___ mins	___ mins
FRI	___ mins	___ mins	___ mins	___ mins
SAT	___ mins	___ mins	___ mins	___ mins
SUN	___ mins	___ mins	___ mins	___ mins

EXTERNAL LIGHTS & ILLUMINATED SIGNAGE

	100% ON	100% OFF
MON	___ mins	___ mins
TUE	___ mins	___ mins
WED	___ mins	___ mins
THU	___ mins	___ mins
FRI	___ mins	___ mins
SAT	___ mins	___ mins
SUN	___ mins	___ mins

APPENDIX C – TRACK LIGHT AIMING INSTRUCTIONS

GENERAL

Adjust all track mounted lights to achieve the below outcomes:

- Main focal points are merchandise, floor fixtures and signage – adjust lights such that higher lighting intensity is achieved on focal points and less on floor and surround.
- Eliminate glare by reducing spotlight tilt angle or by relocating light closer to the display fixture or sign.
- Avoid dark spots and shadows on floor, allow some lights to wash main thorough fare.

LIGHTING MOUNTING HEIGHTS

Refer to the standard lighting concept plan for specific lighting mounting heights. Generally, lighting tracks shall be installed at 3500mm from floor to underside of the track. Where this height cannot be achieved, mount tracks as high as possible. 'Stop and start' track if necessary where ceiling obstruction exists to achieve the required height. The main objective is to achieve a clear line of sight across the trading area and that lights should not obstruct view of perimeter signage.

LIGHTING ADJUSTMENT

Adjust light such that the light beam should be hitting the centre of the display fixture, table or signage, etc... to achieve full coverage. Allow extra lights if necessary should one light is not adequate to illuminate the entire fixture. Relocate and adjust spotlight angle to achieve the required effect.

Examples of lighting adjustment to illuminate wine cabinets and signage

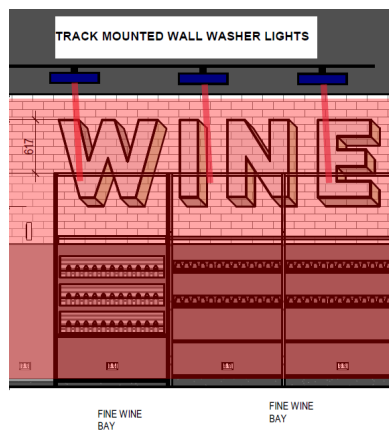
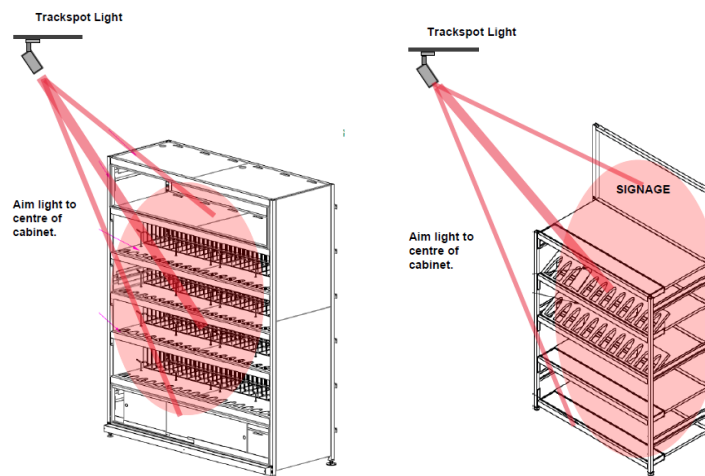

Aim wall wash track lights or spotlights to provide uniform wash of signage and wall.

APPENDIX D – LIGHTING SUSPENSION INSTALLATION GUIDE



LIGHTING SUSPENSION INSTALLATION GUIDE

NOTE: This manual provides guidelines on the installation of the Gripple cable hanger system used for suspending lighting fixtures. Endeavour Group takes no responsibility or accepts any liability on the instructions given herein. Installers are to consult with the manufacturer for correct installation methods appropriate to site conditions and the intended application.

Amendments		
Description	Rev No.	Date
New issue	A	7/10/2021

Table of Contents

1.0	PREAMBLE.....	3
2.0	APPROVED CABLE HANGER SYSTEMS.....	3
3.0	GENERAL REQUIREMENTS.....	3
4.0	GRIPPLE WIRE SUSPENSION SYSTEM.....	5
4.1	BASIC COMPONENTS OF THE GRIPPLE SYSTEM.....	5
4.2	MANUFACTURER'S RECOMMENDATIONS.....	7
5.0	METHODS OF INSTALLATION.....	9
5.1	LOOP METHOD.....	9
5.2	CEILING ANCHOR METHOD.....	10
5.3	PURLIN CLIP METHOD – APPLICABLE TO REFURBS & RETROFIT ONLY.....	12
5.4	HANGING AT ANGLES.....	14
5.5	TERMINATING GRIPPLE FASTENERS.....	16
6.0	SUPPLEMENTARY MOUNTING OPTIONS.....	17
	APPENDIX A – COMPLIANCE CERTIFICATE	
	APPENDIX B – GRIPPLE PRODUCT GUIDES	

Acknowledgements:

Gripple Australia – 'Gripple Product Guide'.

1.0 PREAMBLE

This document provides guidance specifically for the installation of suspended lighting within an Endeavour Group retail site.

It is the responsibility of the installation contractor (refer as “the Contractor” in this document) to follow the manufacturer’s installation instructions to ensure that the whole of the lighting hanger system is safe and effective.

It should also be noted that the Contractor is required to submit a certificate of compliance upon completion of a lighting cable hanger installation. A template of the compliance certificate can be found appended to this document, it shall be signed and submitted to the Endeavour Group Project Manager upon completion of the lighting installation.

2.0 APPROVED CABLE HANGER SYSTEMS

Approved suspension cable hanger systems shall be as follows:

Manufacturer: Gripple
Size: **Gripple No. 1**, safe working load up to 10kg.
Gripple No. 2, safe working load up to 45kg.

Contact: Polyplas International,
30 Sydney Road, Bayswater VIC 3153
Ph (03) 9720 0449 - Mob 0405 238 928
www.griippleaustralia.com.au

The Contractor shall consult with manufacturer and follow their recommended installation procedures. Use only manufacturer’s approved fixing components to ensure strength integrity is maintained as per the manufacturer’s engineered solutions.

Contact Polyplas International Ph (03) 9720 0449, <http://griippleaustralia.com.au> for the latest product guide.

3.0 GENERAL REQUIREMENTS

The lighting suspension system shall meet the following general requirements:

- a) Use **Gripple No. 1 and Gripple No. 2** cable hanger system including stainless steel cables and associated fixing components rated at the same load bearing capacity as the cable.
- b) For track lighting and linear trunking/extrusion lighting, the maximum spacing between **two (2) hangers** shall be as follows:

Gripple No. 1 for Track Lighting:

At 1800mm spacing – maximum of 10kg between two hangers (5.6kg/lineal metre)
At 2400mm spacing – maximum of 10kg between two hangers (4.2kg/lineal metre)

Gripple No. 2 for Linear Trunking/Extrusion Lighting:

At 1800mm spacing – maximum of 45kg between two hangers (18.8kg/lineal metre)
At 2400mm spacing – maximum of 45kg between two hangers (25.0kg/ lineal metre)

For suspending single light fittings, consult Gripple Product Guide for selection of suitably rated Gripple hanger size. Seek advice from the Endeavour Group Electrical Engineer if in doubt.

- c) A cable hanger shall be installed at the beginning of each run of lighting track/trunking, placement of hanger cable shall be **not more than 200mm** from where the track/trunking light starts. Similarly, a cable hanger shall be installed at the end of each run, **not more than 200mm** from where the track/trunking light ends.
- d) Where a building structural member does not exist in the position required for the cable hanger, install a unistrut or similar fixing directly above the light fitting for support.
- e) For stores with a false ceiling and where the suspension wire cannot be attached vertically perpendicular to the light, the cable wire can be installed at a maximum angle of **20°** from vertical. Suspension wires with a greater mounting angle shall have a unistrut or similar fixing installed to support the light fitting vertically.
- f) The following methods **shall not** be employed when installing cable hangers:
 - Suspension wires are not to be joined in any form, including use of a Gripple locking device.
 - Building services structures such as airconditioning ducts (rigid and non-rigid), water pipes, fire sprinkler pipes, cable support systems (cable trays/baskets, ducts), and the like shall not be used as a means to attach the suspension wire.
 - Use of non-approved cable hanger systems other than Gripple or those specified within this document.
 - Use of catenary wires to support hangers unless specifically approved by the Endeavour Group Engineer.
 - Use of non-approved cable locking devices such as grub screw connectors and electrical connectors.
 - Any other prohibited use of the Gripple cable hanger and its associated components as prescribed in the manufacturer's product manuals.

Suspension wire spacing for trunking and track lights

n: 2400 mm max for Gripple #2 - Trunking lights
1800mm max for Gripple #1 - Lighting tracks.

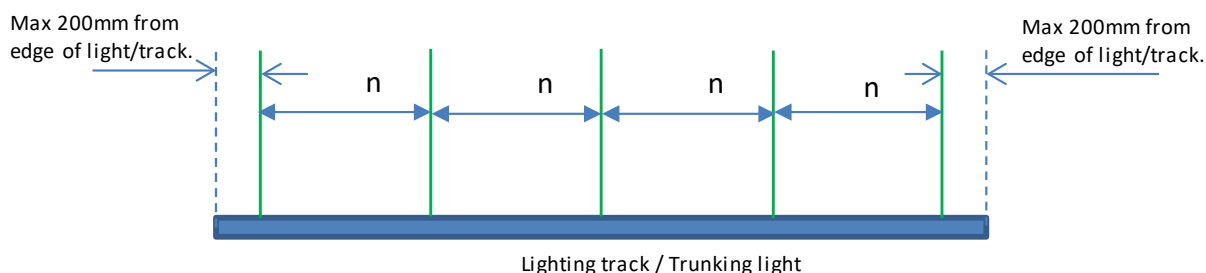

4.0 GRIPPLE WIRE SUSPENSION SYSTEM

4.1 BASIC COMPONENTS OF THE GRIPPLE SYSTEM

(1) Gripple No. 1 for Lighting Tracks

Each Gripple #1 system comprises the following components:

- 1.5mm² gauge stainless steel suspension wire, and
- Proprietary 'Angel' locking mechanism fitted to mounting bracket at lighting track end.

Consult the manufacturer to order adequate wire length to suit the application.

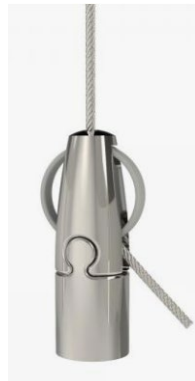

'Angel' locking mechanism

(2) Gripple No. 2 for Trunking Lights

Each Gripple #2 system comprises the following components:

- 2mm² gauge stainless steel suspension wire, and
- Proprietary 'Gripple' locking mechanism fitted to mounting bracket at light fixture.

Consult the manufacturer to order adequate wire length to suit the application.



Stainless steel

Used to suspend a variety of mechanical and electrical services in the food industry and high humidity environments.

- Stainless steel body and springs are corrosion resistant and long-lasting
- Ceramic wedges for extra strength and corrosion resistance
- Aesthetically discreet and lightweight
- Available in two load rated sizes up to 200 lbs
- Supplied as a ready-to-use kit

End fixing choices



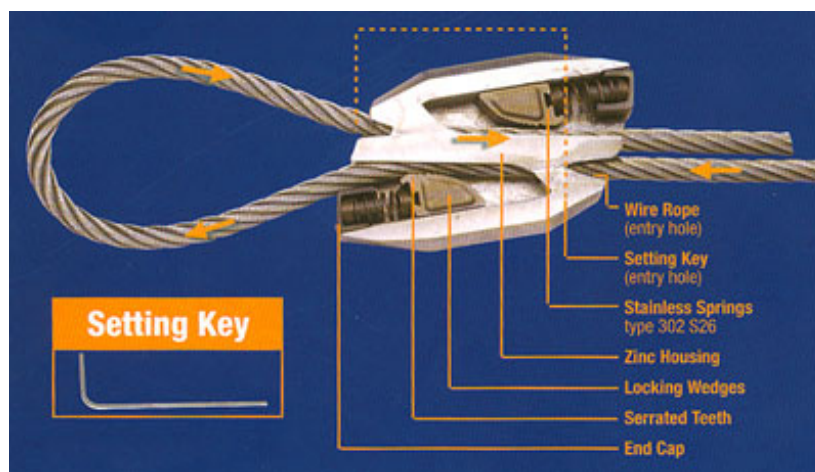

The Gripple #2 Fastener or Locking Device.

(3) Ceiling End Fixings

Use of appropriate anchor fixings or loop wires available from the manufacturer to attach the suspension wire to the ceiling structure. For example, use eyelet anchor to attach wire to slab ceiling.

For new stores where purlin roof structure exist, the Gripple wires shall be secured to the building structure above by mechanically fixing to the purlin web. Where a building structural member does not exist in the position required for the cable hanger, install a unistrut or similar fixing directly above the light fitting for support.

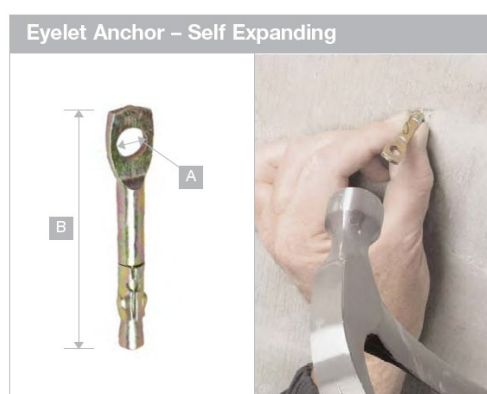

Use of eyelet anchor for slab ceiling

For refurbishments and 'roll-out' projects, Gripple supplied purlin lip clips shall only be used where:

- Maximum load per purlin lip clip shall be equal or less than 10kg.
- Where multiple purlin lip clips are used on a single purlin, these clips shall be spaced greater than 1200mm, but less than the approved spacing distance, i.e. no more than 1800mm for Gripple #1 and 2400mm for Gripple #2.
- Where the purlin is smaller than the tested purlin (i.e. Z20019) a new test shall be carried out to determine suitability.
- Where existing loads on the roof structure exceeds typical allowances, then a structural engineer shall be employed to approve use of this system for these specific circumstances.

4.2 MANUFACTURER'S RECOMMENDATIONS

The Contractor shall strictly adhere to the manufacturer's installation instructions and recommendations when using the Gripple product.

GRIPPLE HANGER - DO'S

- Ensure that the cable protrudes at least 3 inches from the Gripple housing
- Use Gripple hangers for suspending static loads only
- Use the hanger within its stated load range
- Check that the self-locking fastener is fully engaged
- Ensure all hangers are evenly loaded
- Keep the hanger components clean
- Follow the manufacturer's recommendations
- Consider the effect of an angle, or forming in-line joints, has on the SWL
- Follow health and safety guidelines and best practice recommendations in the workplace
- Ensure appropriate PPE is worn when handling cable

GRIPPLE HANGER - DONT'S

- Exceed the product's Safe Working Load
- Use the hanger for lifting
- Use the hanger for moving services
- Splice together two Gripple hanger kits, or any other joining device
- Walk on any suspended service
- Use the self-locking fasteners on coated wire of any kind
- Apply paint to the Gripple faster. Ensure that the Gripple is in its final position and protected with a Decor cover prior to applying any paint to the cable assembly. Do not move the Gripple after painting.
- Apply lubricants or other coatings to the Gripple or cable
- Use standard hangers in a chlorinated or humid atmosphere
- Exceed an angle of 60°
- Attempt to use the setting key when the suspension is under load
- Re-use Gripple hangers; they are designed for permanent installations

Manufacturer's recommendations

Failure to comply with these recommendations may result in product malfunction and possible damage to property or person, and will invalidate the Gripple warranty. Gripple products are warranted to conform to the manufacturer's published specifications at the time of shipment and to be free from defects in materials and workmanship. No other warranty, whether expressed or implied including any warranty of merchantability or fitness for purpose, shall exist in connection with the sale or use of any Gripple product.

Full technical information and installation instructions should be obtained directly from Gripple Limited, Gripple Europe, Gripple Inc, any regional Gripple office or via the website www.gripple.com.

Please respect and embrace the following key recommendations:



Loads - Always operate the product within its stated safe working load range.



Lifting - Do not use for lifting, either as a crane or as part of a pulley system, or for hanging services exhibiting moving or dynamic behaviour. Designed for hanging statically positioned services.



Installation - Do not walk or stand on the Gripple product installation.



Painting - Do not paint the Gripple hanger. Ensure that the Gripple hanger is in its final position and protected with the Decor cover prior to applying any paint to the wire rope assembly. Do not move the Gripple hanger after painting.



Lubrication - Do not apply oil or any other lubricant to the Gripple hanger or any other part of the assembly.



Wire rope - Always use the Gripple hanger supplied and specified wire rope. Never use on coated wire rope or other rope. Trim any damaged filaments with Wire cutters before use.



Environment - Do not use in acid and chlorinated atmospheres. Use standard Gripple hangers in dry and air conditioned environments only. Stainless steel hangers should be considered for high to saturated humid environments.



Joining - Never join two ends together in line. Only pass the free end of the wire rope in a continuous loop through both channels of the Gripple hanger. The angle inside the Gripple formed loop must not exceed 60°.



Hanging at an angle to vertical - Ensure that the load calculation considers the effect of 'side load'. For example, at an angle of 60° to vertical the SWL is reduced by 50% (See technical information on page 76).



Ducting: When installing wrap around hangers on round / spiral ducting or pipes, the final inclusive angle of the assembly should not exceed 60°.



Y-Fit: Legs on Y-Fits not to be installed greater than 60°.

Quality and approval

Quality is everything to Gripple; not just in the products we make and the manufacturing process we employ, but the way we do business. Our compliance to the International Organisation for Standardisation BS EN ISO9001 at our Sheffield manufacturing plant is the backbone of our own quality management system and we are proud to have achieved this through the reputable LRQA.

5.0 METHODS OF INSTALLATION

Following are three common installation methods using Gripple wires to suspend lights. Apply appropriate fixing method to suit the building structure. In all cases, the Contractor is to consult the manufacturer on the correct method of installing the cable hangers including use of appropriate fixing components.

5.1 LOOP METHOD

Suspension wire is wrapped looped around purlins, beams roof trusses and other accessible building structures. This method is applicable where a false ceiling exists. Where trade area has exposed ceiling, cable hangers shall be fixed to the purlin web or directly to the ceiling slab.

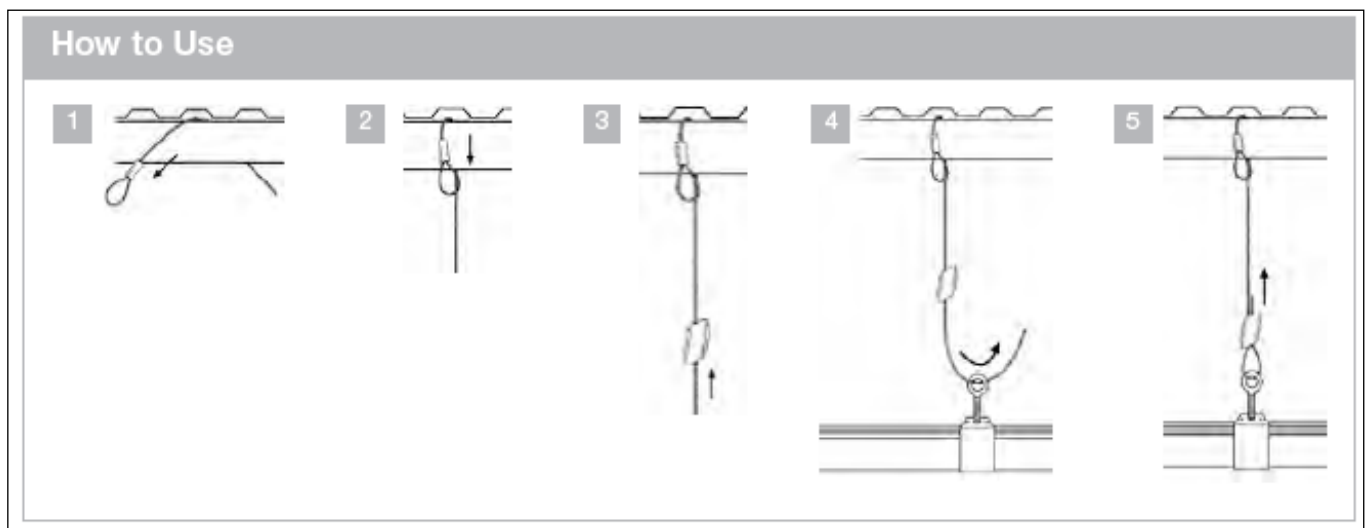
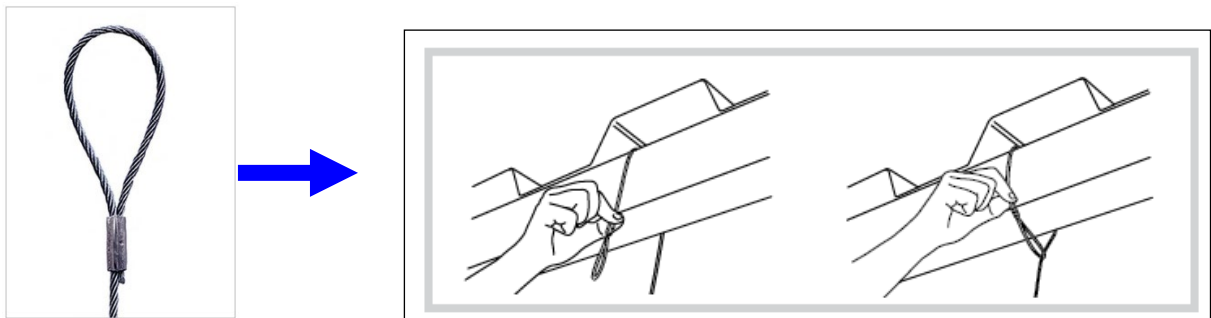

5.2 CEILING ANCHOR METHOD

Ceiling anchors such as those shown below are to be installed directly into the concrete slab. Ceiling anchors are to come complete with a suspension wire of appropriate length to suit the application.



Ring anchor

- Ideal for fixing into concrete and cracked concrete
- Shallow anchorage depth of 25 mm
- Available up to 45 kg SWL, with a 3:1 safety factor
- Comes as a ready-to-use kit with wire and Gripple hanger
- Available in lengths from 1 to 10 m
- Other lengths are available on request

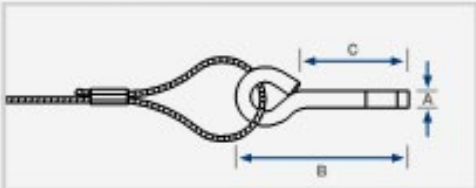

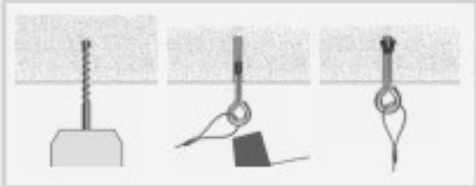

Size	A (mm)	B (mm)	C (mm)
No.2 (10 - 45 kg)	6	64	35

Install fixings in accordance with manufacturers' specifications.





Related accessories

Page 43

Page 71



Page 71

Page 69

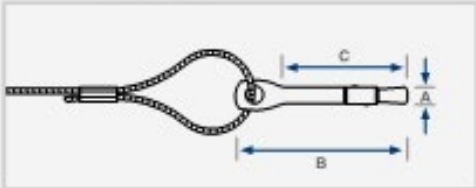

Ceiling anchor

- Ideal for fixing hangers into concrete ceilings
- Knock into a pre-drilled hole, pull with a claw hammer to set
- Available up to 45 kg SWL, with a 3:1 safety factor
- Comes as a ready-to-use kit with wire and Gripple hanger
- Available in lengths from 1 to 10 m
- Other lengths are available on request



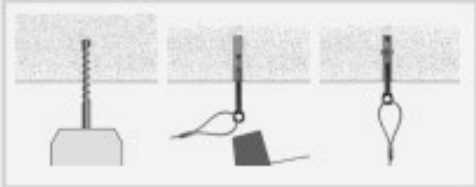

Size	A (mm)	B (mm)	C (mm)
No.2 (10 - 45 kg)	6	65	50

Install fixings in accordance with manufacturers' specifications.



Related accessories

Page 74

Page 71

Page 71

Page 69

www.gripple.com **65**

10

The most common option for concrete anchors that Gripple supplied with their No. 2 suspension kit is the 'Powers 5mm Tie Wire spike' as detailed below.



Working stress design – carbon steel, Tie-Wire SPIKE®

Allowable working load capacities for Tie-Wire SPIKE								
ANCHOR SIZE mm	DRILL SIZE mm	EMBEDMENT DEPTH mm	20 MPa concrete		32 MPa concrete		40 MPa concrete	
			Tension kN	Shear kN	Tension kN	Shear kN	Tension kN	Shear kN
5	5	32	1.2	1.2	1.3	1.2	1.4	1.2
6.5	6.5		1.4	1.6	1.4	1.6	1.6	1.6

NOTE: Incorporated safety factor (Tension and shear) $F_{sc} = 3$ (concrete).

Limit state design – carbon steel, Tie-Wire SPIKE®

Limit state design load capacities for Tie-Wire SPIKE								
ANCHOR SIZE mm	DRILL SIZE mm	EMBEDMENT DEPTH mm	20 MPa concrete		32 MPa concrete		40 MPa concrete	
			Tension kN	Shear kN	Tension kN	Shear kN	Tension kN	Shear kN
5	5	32	2.2	2.1	2.4	2.1	2.6	2.1
6.5	6.5		2.4	3.0	2.6	3.0	2.8	3.0

NOTE: Incorporated strength reduction factor (Tension and shear) $\phi = 0.6$

Mounting Instructions

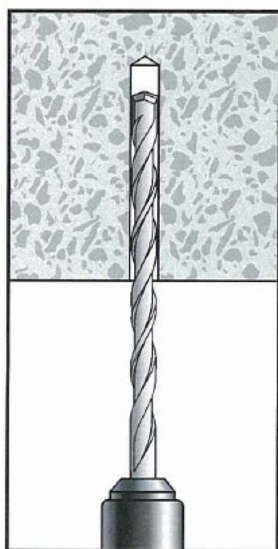

Using the proper diameter bit, drill a hole into the base material to a depth of at least one anchor diameter deeper than the embedment required

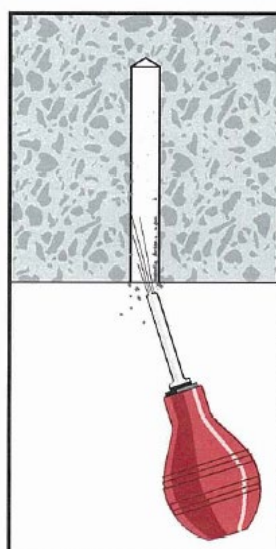

Blow the hole clean of dust and other material.

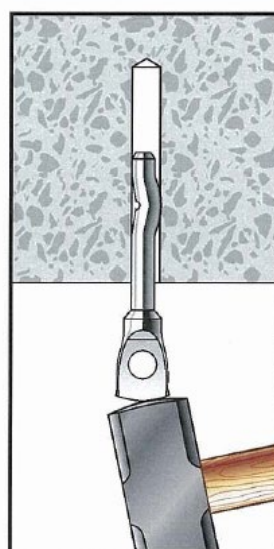

Drive the anchor into the anchor hole until the head is firmly seated against the concrete.

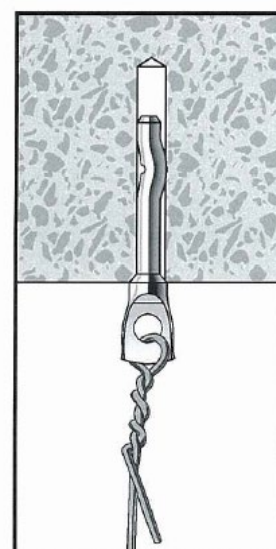

Attach wire through eyelet.

5.3 PURLIN CLIP METHOD – APPLICABLE TO REFURBS & RETROFIT ONLY

For refurbishments and retrofit projects only, Gripple supplied purlin clips can be used subject to the following conditions:

- (1) The purlin size is **equal or greater** than C section purlin C200-19 and Z section purlin Z200-19. Where the purlin is smaller than the above specified purlins, load tests shall be carried out to determine its suitability for clip attachment.
- (2) Maximum load per purlin clip shall be equal or less than 10kg.
- (3) Where multiple purlin lip clips are used on a single purlin, these clips shall be spaced greater than 1200mm, but less than or equal to 1800mm for Gripple #1 and 2400mm for Gripple #2, and
- (4) Where existing loads on the roof structure exceeds typical allowances, then a structural engineer shall be employed to approve use of this system for these specific circumstances.

Sizes

The table below lists the standard sizes and thicknesses readily available. For sections outside this range please contact your local Stramit office.

C Sections

C Sections are mono-symmetric sections. Their freestanding, stable shape allows easy handling and storage and is adaptable to 'I' and 'box' configurations.

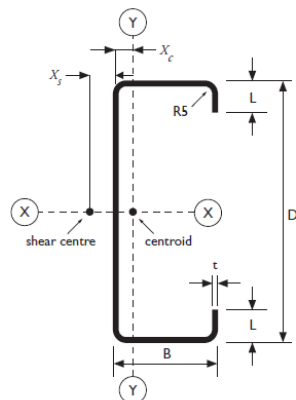

Z Sections

Z Sections are asymmetric sections. The uneven flange widths allow the sections to be lapped to permit structural continuity, a factor that contributes significantly to building economies. Savings achieved by lapping Z sections, resulting from the increase in strength and rigidity, more than compensate for the extra purlin material required in the lap itself.

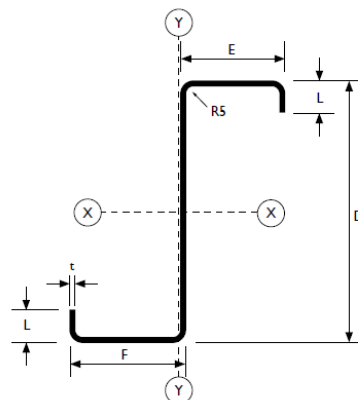

C SECTION SIZE RANGE							Z SECTION SIZE RANGE					
Section	Web D	Flange B	Lip L	Thickness t	X _c	X _y	Section	Web D	Flange E	Flange F	Lip L	Thickness t
	mm	mm	mm	mm	mm	mm		mm	mm	mm	mm	mm
C100-10	102	51	12.5	1.0	16.1	25.8	Z100-10	102	49	53	12.5	1.0
C100-12	102	51	13.0	1.2	16.2	26.0	Z100-12	102	49	53	13.0	1.2
C100-15	102	51	14.0	1.5	16.3	26.2	Z100-15	102	49	53	14.0	1.5
C100-19	102	51	15.0	1.9	16.4	26.5	Z100-19	102	49	53	15.0	1.9
C150-10	152	64	14.5	1.0	18.4	30.1	Z150-10	152	61	65	14.5	1.0
C150-12	152	64	15.0	1.2	18.5	30.3	Z150-12	152	61	65	15.0	1.2
C150-15	152	64	16.0	1.5	18.6	30.5	Z150-15	152	61	65	16.0	1.5
C150-19	152	64	17.0	1.9	18.7	30.8	Z150-19	152	61	65	17.0	1.9
C150-24	152	64	18.5	2.4	18.9	31.1	Z150-24	152	61	66	18.5	2.4
C200-15	203	76	16.0	1.5	20.1	33.6	Z200-15	203	74	79	16.0	1.5
C200-19	203	76	19.5	1.9	20.9	34.9	Z200-19	203	74	79	19.5	1.9
C200-24	203	76	21.0	2.4	21.1	35.2	Z200-24	203	74	79	21.0	2.4
C250-19	254	76	19.0	1.9	18.3	32.2	Z250-19	254	74	79	19.0	1.9
C250-24	254	76	20.5	2.4	18.4	32.5	Z250-24	254	74	79	20.5	2.4
C300-24	300	96	28.0	2.4	25.0	42.7	Z300-24	300	93	100	28.0	2.4
C300-30	300	96	31.5	3.0	25.8	44.0	Z300-30	300	93	100	31.5	3.0
C350-30	350	125	30.0	3.0	33.3	55.0	Z350-30	350	121	129	30.0	3.0

Courtesy: Stramit Purlins, Girts & Bridging Technical Manual.

Following are two types of purlin clips commonly used to attach the suspension wire onto the lip of the purlin.

(a) Vertical Flange Clip - suitable for Purlins with Vertical Section

SIZE SAFE WORKING LOAD	LENGTH (M)	BAG QTY	Purlin Clip End (Suit 1.6 - 2.5mm purlin)	
				Codes
No.1 10kg	1	10	HF01-1M-PC	
	2	10	HF01-2M-PC	
	4	10	HF01-4M-PC	
	6	10	HF01-6M-PC	
	10	10	HF01-10M-PC	
No.2 45kg	1	10	HF02-1M-PC	
	2	10	HF02-2M-PC	
	3	10	HF02-3M-PC	
	4	10	HF02-4M-PC	
	6	10	HF02-6M-PC	
	10	10	HF02-10M-PC	

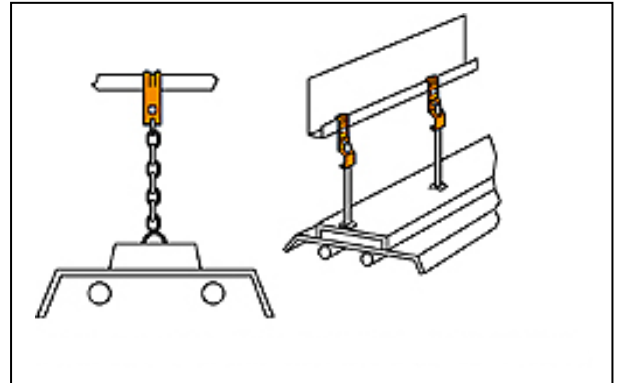

(b) Z Purlin Clip – suitable for Angled Purlin Section

Z Purlin clip

- Hammer-on installation
- Available to suit 2.5 mm maximum flange thickness
- Ideal for use with the Snap hook end fixing (page 58)

3:1 Safety rating

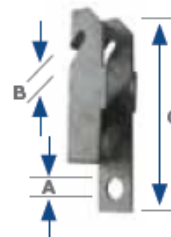

Product code	A (mm)	B (mm)	C (mm)	Max. SWL (kg)	Quantity
GCZP48	6.5	2.5	48	72	100

5.4 HANGING AT ANGLES

Where the suspension wire cannot be installed vertically to the light fitting, a trapeze supporting structure using unistruts or equivalent shall be provided to suspend the light fitting. In instances where there is a false ceiling, the wire can be suspended at a maximum of 20° angle, however additional support systems such as a trapeze structure shall be employed should the mounting angle exceeds this limit. Further explanation of the two methods is outlined below.

(a) Trapeze Structure for false ceiling or open ceiling

This method applies to both open ceiling and false ceiling installations where (i) the mounting angle is greater than 20°, (ii) no building supporting structure directly above the light fitting such as purlins, (iii) there are building services such as AC ducts, cable trays, water pipes, etc... obstructing the installation of the suspension wire.

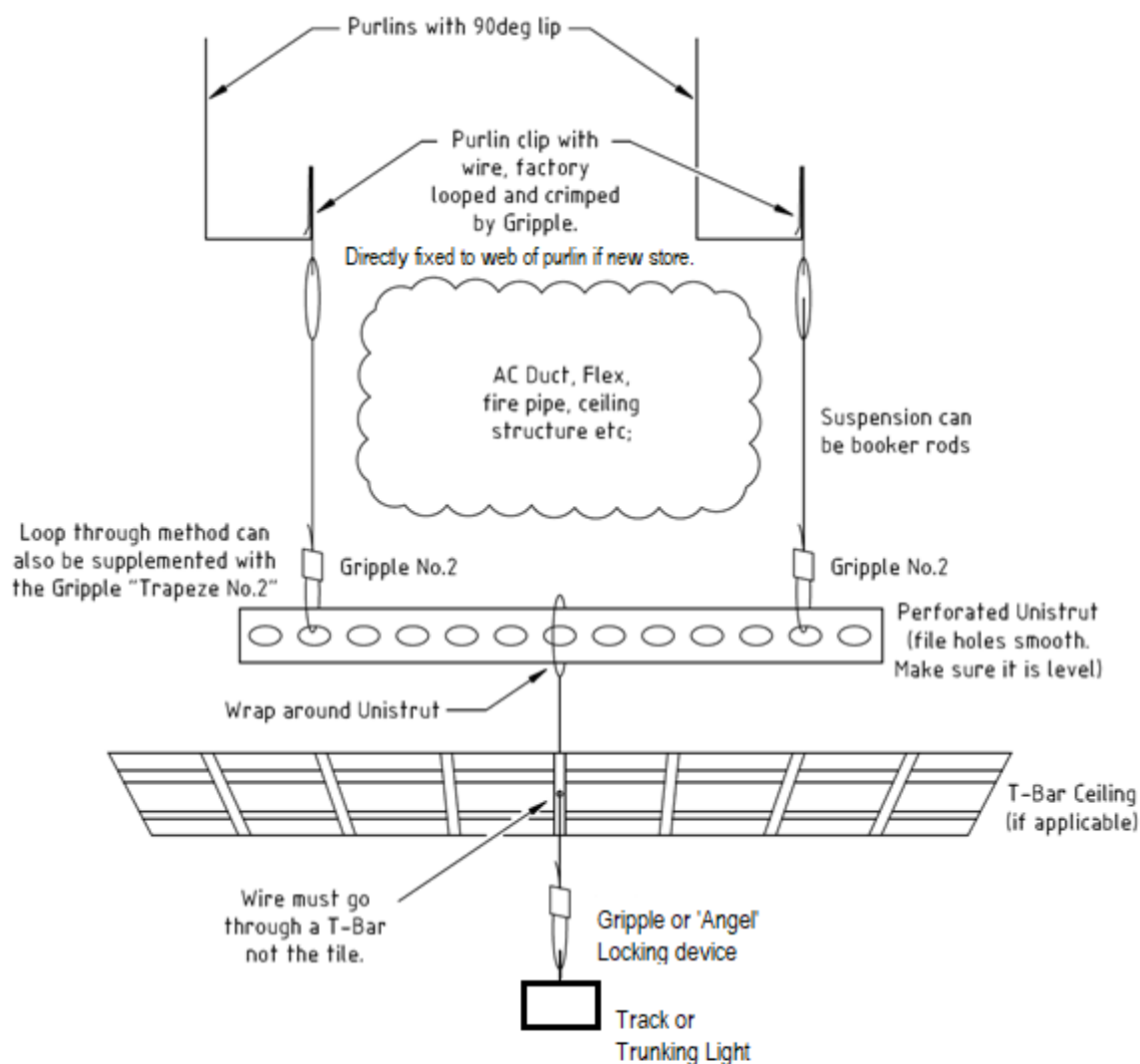

Notes:

- 1) Purlin clips must suit the purlin. Caddy or Gripper Z purlin clips can be used on purlins with a 45deg lip.

TRAPEZE STRUCTURE FOR FALSE CEILING OR OPEN CEILING

(b) Where a store has a false ceiling

The following method is only applicable to where a store has a false ceiling.

The suspension wire is to pass through a pre-drilled hole on the T-bar frame and NOT on the ceiling tile. Ensure the hole is free from burr so as not to damage the stainless steel wire.

The suspension wire can deviate from vertical at the point of attachment and at the T-bar at a maximum angle of **20°**. Any greater angle will significantly reduce the loading capacity of the suspension wire as well as increasing stress on the T-bar ceiling structure.

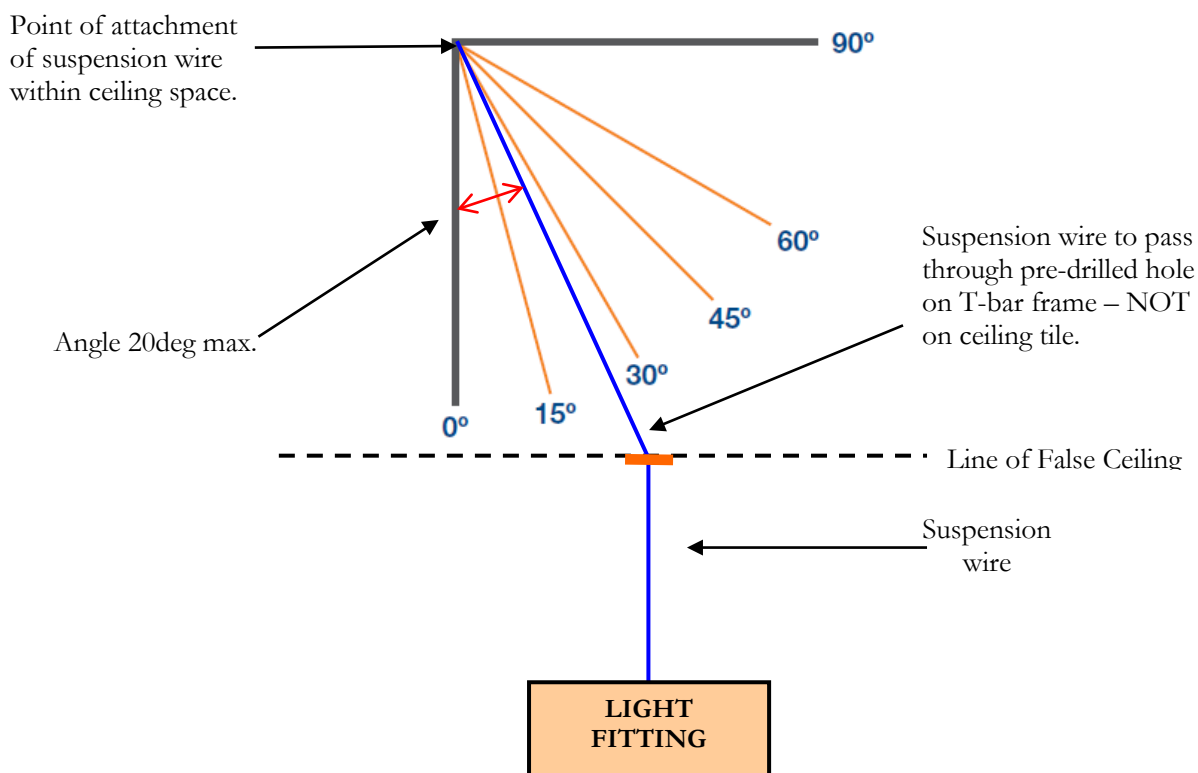

Note: Effect on Safe Working Load of hanging objects at an angle

The load rating for a Gripper Hanger is based on the suspension being hung vertically. If the wire rope is suspended at an angle, an additional sideways load is applied which reduces the load capacity of the suspension. The net effect is shown in the table below.

Hanger size	Maximum load (kg) at an angle from vertical				
	0°	15°	30°	45°	60°
No.1	10	9.6	8.6	7	5
No.2	45	43	39	32	22
No.3	90	87	78	64	45
No.4	225	217	195	159	113
No.5	325	314	281	230	163
Load %	100	96	86	70	50

No Gripper hanger should be hung at an angle in excess of 60° from vertical.

5.5 TERMINATING GRIPPLE FASTENERS

The Gripple #2 fastener shall be placed at a distance of 80mm from the top of the light fitting. The excess wire passing through the top of the Gripple fastener shall have a length of 80mm as per the manufacturer's recommendation. Where the Gripple fasteners are visible to customers, strap the 80mm excess wire to the main cable using white cable ties.

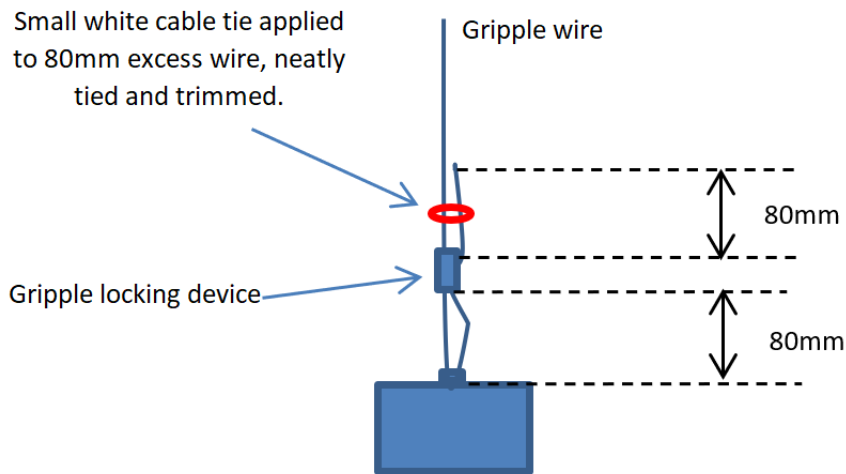

Track or trunking light using Gripple #2 locking device

Where Gripple #1 with 'Angel' fastener shall have a 50mm excess tail as shown in the below diagram.

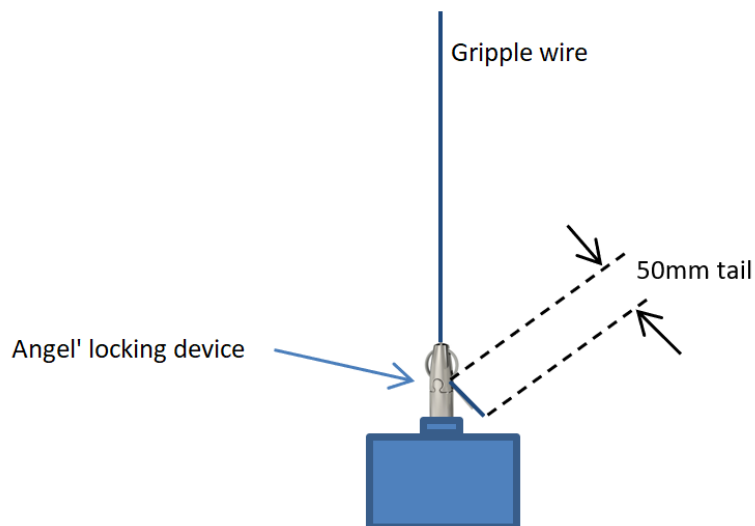

Track or trunking light using 'Angel' locking device

6.0 SUPPLEMENTARY MOUNTING OPTIONS

1. Use of Gripple #2 Fasteners for suspending LED trunking lights directly below false ceiling

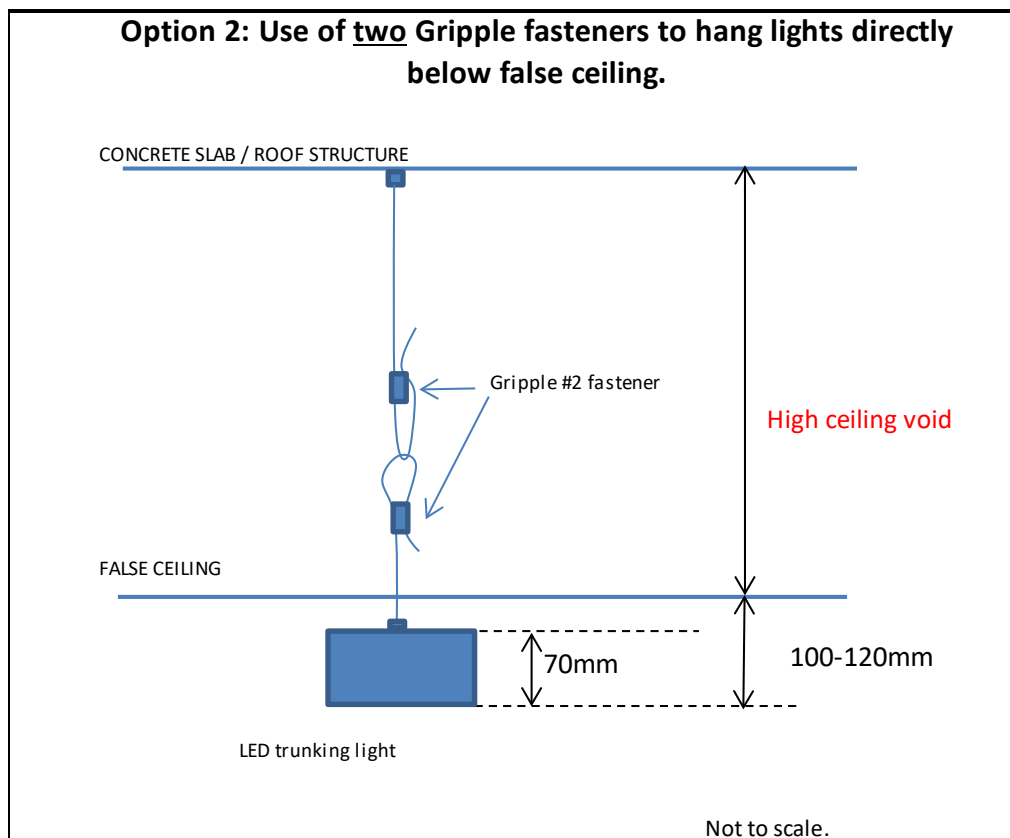
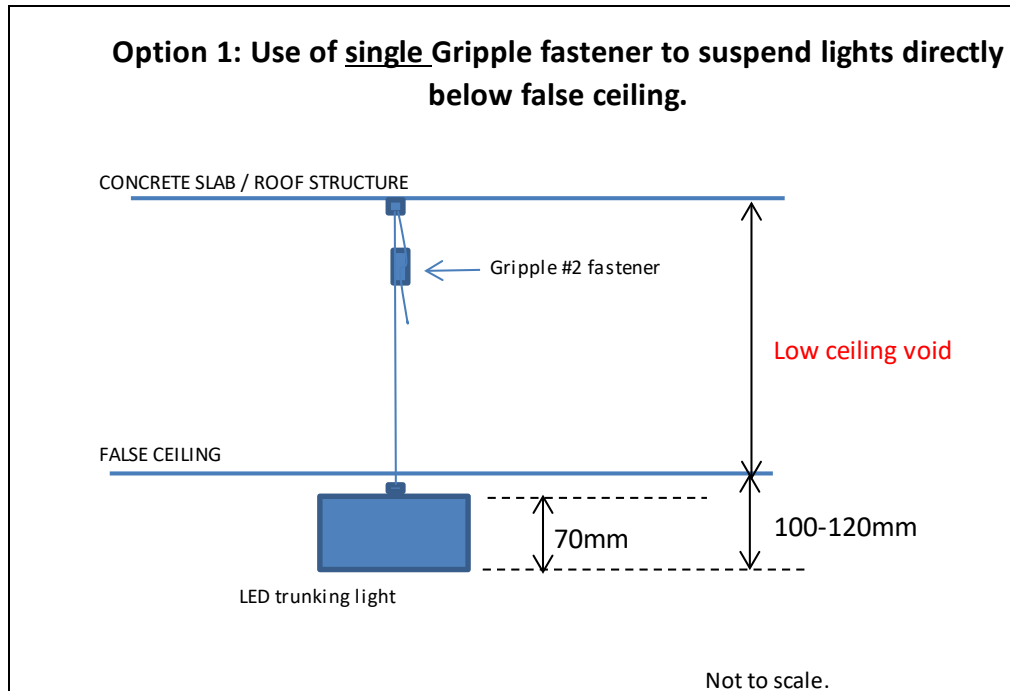

2. Mounting lighting tracks directly below false ceiling using Gripple #1 with Angel fastener.

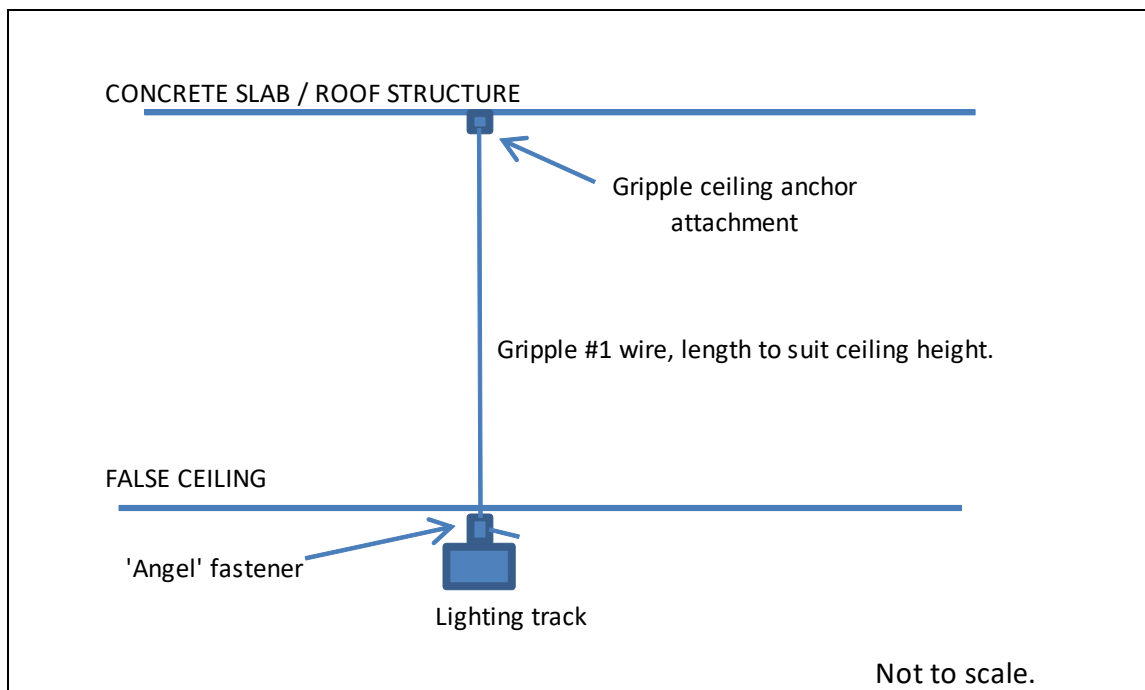

APPENDIX A
LIGHTING SUSPENSION SYSTEM
COMPLIANCE CERTIFICATE

Store name: **Store number:**

Date work completed:

Electrical Contractor:

We certify that the lighting suspension system installed at the above installation has been completed in accordance with the manufacturer’s recommendations and ‘Endeavour Group Lighting Suspension Installation Guide’. Specifically the following items have been met in the installation of the lighting suspension system:

a) Gripple lighting suspension hangers installed as follows (cross out where not relevant):

Gripple No. 1 for Track Lighting:

At 1800mm spacing – maximum of 10kg between two hangers (5.6kg/m)

At 2400mm spacing – maximum of 10kg between two hangers (4.2kg/m)

Gripple No. 2 for Linear Trunking/Extrusion Lighting:

At 1800mm spacing – maximum of 45kg between two hangers (18.8kg/m)

At 2400mm spacing – maximum of 45kg between two hangers (25.0kg/m)

b) Cable hangers were installed at start and end of each lighting track/trunking light with placement of hangers not more than 200mm from each end.

c) Where there were no building structural members directly above the light fittings or there were obstructions from building services, unistruts or similar fixings were installed to support the lighting.

d) For store that has a false grid ceiling, cable hangers were installed at no more than 20° angle to vertical.

e) The following methods were not employed when installing cable hangers:

- Suspension wires were not joined in any form, even with use of a Gripple locking device.
- Building services structures such as airconditioning ducts (rigid and non-rigid), water pipes, fire sprinkler pipes, cable support systems (cable trays/baskets, ducts), and the like were not used as a means to attach the suspension wire.
- Use of non-approved cable hanger systems other than Gripple or those specified within the Lighting Suspension Installation Guide.
- Use of catenary wires to support suspension wires.
- Use of non-approved cable locking devices such as grub screw connectors and electrical connectors.
- Any other prohibited use of the Gripple cable hanger and its associated components as prescribed in the manufacturer’s product manuals.

Signed: Date

Name:

Position: Contact number:.....

Company:

A signed copy of this certificate shall be provided as follows (1) to Endeavour Group Project Manager, (2) included in the Operation & Maintenance manuals, (3) a soft copy emailed to engineering@woolworths.com.au

Failure to comply may result in withhold of payments.

**APPENDIX B
GRIPPLE PRODUCT GUIDES**

Contact Polyplas International
Ph (03) 9720 0449
<http://grippleaustralia.com.au/>
for the latest product guide.